

# Experiment 1: Resistors

## Student Group

First Name	Surname	Matrikel Nr.

## Table of Contents

- Experiment 1: Resistors** ..... 2
  - Objectives of the Experiment*** ..... 2
  - Preparation for the lab*** ..... 2
- Resistance measurement** ..... 2
  - Direct resistance measurement ..... 2
  - Indirect resistance measurement ..... 4
- Loop law** ..... 5
  - Node law*** ..... 7
- Voltage divider as voltage source** ..... 9
- Non-linear resistors** ..... 11
  - Preparation for the oral short test*** ..... 14

# Experiment 1: Resistors

## Objectives of the Experiment

Getting to know the following components

- Digital multimeter
- Function generator
- Breadboard

Applying

- direct/indirect resistance measurement
- resistor standard series
- mesh/node equations
- differential resistance of an incandescent lamp

## Preparation for the lab

## Resistance measurement

Procedure for resistance measurement:

1. Set the measuring device to resistance measurement.
2. Connect the resistor to be measured to the corresponding sockets on the measuring device (the sockets labelled COM and  $\Omega$ ).
3. Read the measured value.

There are different types of resistance measurement:

- **direct** resistance measurement
- **indirect** resistance measurement

### Direct resistance measurement

Determine the nominal and measured values of the resistance for  $R_{\text{1}}$  (brown, green, orange),  $R_{\text{2}}$  (yellow, violet, red),  $R_{\text{3}}$  (red, violet, red), and the incandescent lamp  $R_{\text{L}}$ . Also measure the approximate resistance  $R_{\text{K}}$  of your body from your right hand to your left hand.

	$R_{\text{1}}$	$R_{\text{2}}$	$R_{\text{3}}$	$R_{\text{L}}$	$R_{\text{K}}$
nominal value					
measured value					

Tab. 1: Direct resistance measurement

How do you explain the deviation between  $R_{\text{L,nominal}}$  and  $R_{\text{L,meas}}$ ?

What consequences can  $R_{\text{K}}$  have?

Now determine the series and parallel combinations of resistors  $R_{\text{1}}$ ,  $R_{\text{2}}$  and  $R_{\text{3}}$ .

State the formulae used:

$$R_{\text{series}} = R_{\text{a}} + R_{\text{b}}$$

$$R_{\text{parallel}} = R_{\text{a}} \parallel R_{\text{b}} = \frac{R_{\text{a}} \cdot R_{\text{b}}}{R_{\text{a}} + R_{\text{b}}}$$

	R1+R2	R1+R3	R2+R3	R1    R2	R1    R3	R2    R3
calculated						
measured						

Tab. 2: Series and parallel combinations

### Indirect resistance measurement

Resistance can also be determined by measuring current and voltage.

**Ohm's law:** In an electrical circuit, the current increases with increasing voltage and decreases with increasing resistance.

$$I = \frac{U}{R}$$

Build the measurement circuit shown in figure 1 for each of the three resistors and set the voltage on the power supply to 12 V.

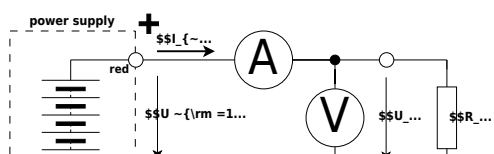

Fig. 1: Indirect resistance measurement

Measure  $U_{\text{n}}$  and  $I_{\text{n}}$ . Calculate  $R_{\text{n}}$  from these values.

Tab. 3: Indirect resistance measurement

# Loop law

**Kirchhoff's voltage law:** In every closed loop of an electrical network, the sum of all voltages is zero.

Set the voltage on the power supply to  $12 \text{ V}$  and measure this voltage accurately using a multimeter. Build the measurement circuit shown in figure 2.

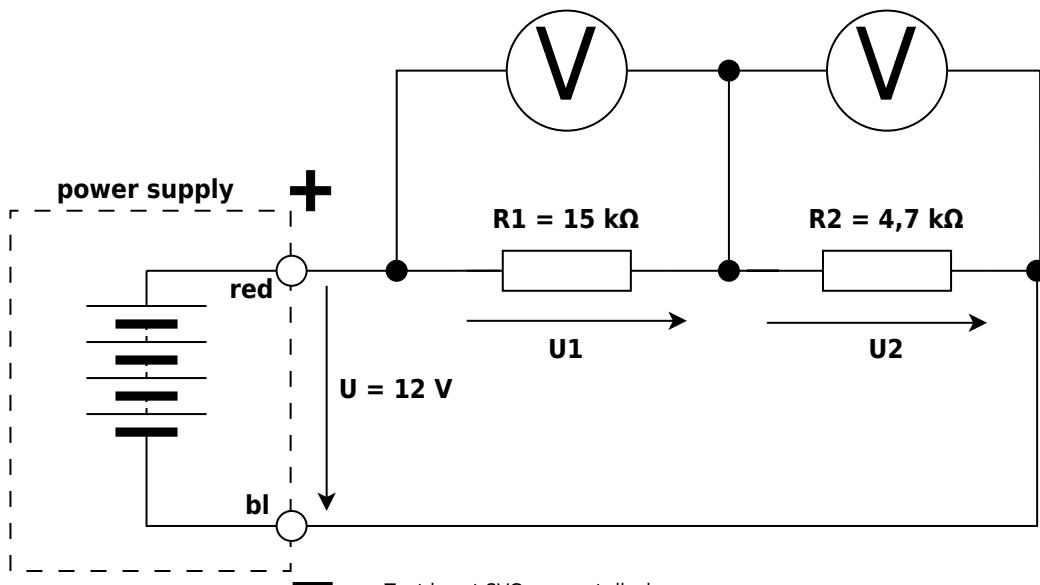

Text is not SVG - cannot display

Fig. 2: Verification of

Kirchhoff's voltage law

Add the voltage arrows and measure  $U$ ,  $U_{\text{1}}$  and  $U_{\text{2}}$ .

$U$	$U_{\text{1}}$	$U_{\text{2}}$

Tab. 4: Voltage measurement for Kirchhoff's voltage law

What is the loop equation here?

Verify the equation using the measured values.

The resistors  $R_{\text{1}}$  and  $R_{\text{2}}$  connected in series form a voltage divider. In what ratio are the voltages  $U_{\text{1}}$  and  $U_{\text{2}}$ ?

$$\frac{U_{\text{1}}}{U_{\text{2}}} =$$

# Node law

**Kirchhoff's current law:** At every node, the sum of all currents flowing into and out of the node is zero.

Set the voltage on the power supply to  $12 \text{ V}$  and measure the voltage accurately using a multimeter. As a first step, build the measurement circuit shown in [figure 3](#).

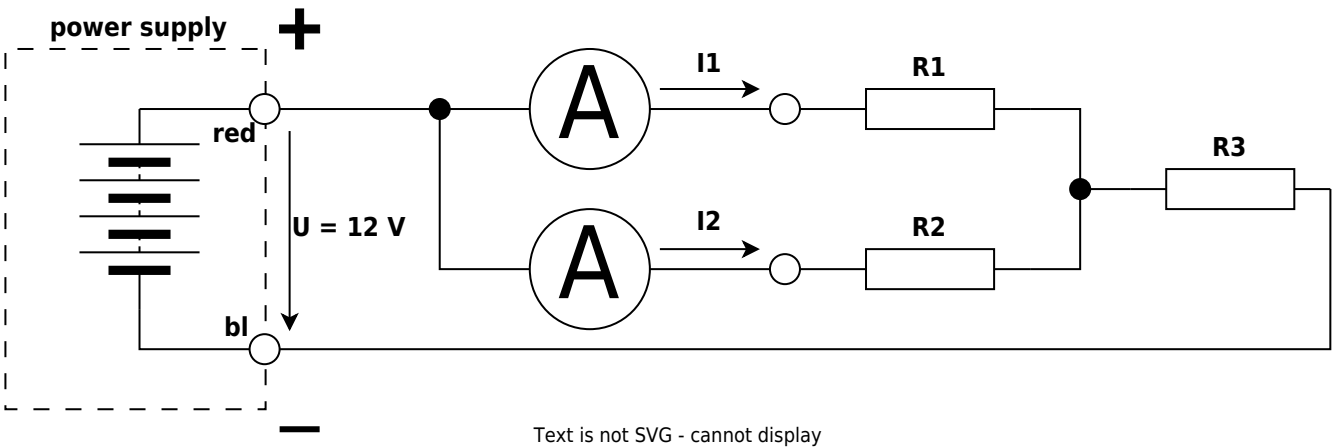

Fig. 3: Branch currents for verification of Kirchhoff's current law

Add the arrows indicating the directions of currents  $I_1$  and  $I_2$ . On both multimeters, set the DC current range and the polarity before switching on. Then measure currents  $I_1$  and  $I_2$  and enter the measured values in the table.



Fig. 4: Total current and node  $K$

In what ratio are currents  $I_1$  and  $I_2$ ?

$$\frac{I_1}{I_2} =$$

Switch the power supply on again and measure the current  $I$ . Enter its value in the table.

$I$	$I_1$	$I_2$

Tab. 5: Current measurement for Kirchhoff's current law

Determine the node equation for node  $K$  and verify its validity.

Using the measured values of resistors  $R_1$ ,  $R_2$  and  $R_3$ , calculate the total resistance  $R_{KP}$ .

Using the calculated value of  $R_{KP}$ , verify the measured value of the total current:

$$I = \frac{U}{R_{KP}} =$$

# Voltage divider as voltage source

The voltage divider shown in [figure 5](#) is initially in the unloaded condition, because the entire current supplied by the power supply flows through the series-connected resistors  $R_{\text{1}}$  and  $R_{\text{2}}$ . A resistor connected in parallel with  $R_{\text{2}}$  loads the voltage divider.

Set the voltage on the power supply to  $12 \text{ V}$  and measure the exact voltage with a multimeter.

For the connected load  $R_{\text{L}} = 10 \text{ k}\Omega$ , the voltage divider represents a voltage source. Like any voltage source, it has a source voltage  $U_0$  and an internal resistance  $R_{\text{i}}$ .

The internal resistance of the voltage divider, considered as a voltage source, results from the parallel combination of the divider resistors  $R_{\text{1}}$  and  $R_{\text{2}}$ :

$$R_{\text{i}} = R_{\text{1}} \parallel R_{\text{2}} = \frac{R_{\text{1}} \cdot R_{\text{2}}}{R_{\text{1}} + R_{\text{2}}}$$

Use the measured values of resistors  $R_{\text{1}}$  and  $R_{\text{2}}$  to calculate the internal resistance  $R_{\text{i}}$  of the voltage source and determine the source voltage:

$$R_{\text{i}} =$$

$$U_0 =$$

The power  $P_0$  supplied by the power supply can be calculated using:

$$P_0 = U \cdot I_{\text{1}}$$

The power consumed by the load resistor can be determined using:

$$P_{\text{L}} = R_{\text{L}} \cdot I_{\text{2}}^2$$



Fig. 5: Loaded voltage divider

Draw the equivalent voltage source of the voltage divider.

What value would  $U_{\text{2}}$  have without  $R_{\text{L}}$ ?

$$U_{\text{2,0}} =$$

Calculate  $U_{\text{2L}}$  and  $I_{\text{2}}$  for  $R_{\text{L}} = 10 \text{ k}\Omega$  using the values of the equivalent voltage source. State the formulae used.

$$U_{\text{2L}}:$$

$$I_{\text{2}}:$$

Verify the values by measurement.

$$U_{\text{2L,meas}}:$$

$$I_{\text{2,meas}}:$$

Verify the values using Kirchhoff's laws. State the formulae used.

$$U_{\text{2L}}:$$

$$I_{\text{2}}:$$

# Non-linear resistors

All resistors examined so far are linear resistors, for which the characteristic  $I = f(U)$  is a straight line; see [figure 6](#). The resistance of a linear resistor is independent of the current  $I$  flowing through it and of the applied voltage  $U$ .



Fig. 6: Characteristic of a linear resistor

For non-linear resistors, there is no proportionality between current and voltage. The characteristic of such a resistor is shown in [figure 7](#). For these resistors, one distinguishes between static resistance  $R$  and dynamic (or differential) resistance  $r$ .

The static resistance is determined for a specific operating point: at a given voltage, the current is read from the characteristic. The calculation is carried out according to Ohm's law:

$$R = \frac{U}{I}$$

The dynamic resistance around the operating point is calculated from the current difference caused by a change in the applied voltage:

$$r = \frac{\Delta U}{\Delta I}$$

Fig. 7: Characteristic of a non-linear resistor

An incandescent lamp is investigated as an example of a non-linear resistor. Build the measurement circuit shown in [figure 8](#).

**power supply** +  
Fig. 8: Measurement circuit for incandescent lamp

Set the voltage on the power supply to the voltage values from [table 6](#). Measure the corresponding current values and enter them in [table 6](#).

U [V]	0.5	1.0	2.0	3.0	4.0	5.0	6.0	7.0	8.0
I [mA]									

Tab. 6: Measured values for the incandescent-lamp characteristic

Plot the characteristic  $I = f(U)$ .

Calculate the static resistance  $R$  at the operating point  $U = 7.0 \text{ V}$ .

Calculate the dynamic resistance  $r$  at the operating point  $U = 7.0 \text{ V}$ .

Compare the values with those from the direct resistance measurement ([table 1](#)).

## Preparation for the oral short test

For this experiment you should

1. be able to apply and explain the following concepts:
  1. current- and voltage-correct measurement
  2. series and parallel connection of resistors
  3. mesh and node equations (Kirchhoff's laws)
  4. passive sign convention and active sign convention
  5. ideal and real sources

You should be able to answer the following questions:

1. Which operating mode does the source use? Which quantity is kept constant by the source?
2. Power supplies operate in quadrants. In which quadrant is the power supply operated? What can the source then correspondingly not do?
3. What must be considered for the (loaded and unloaded) voltage divider?
4. How do you measure a voltage with a current meter? How a current with a voltage meter?
5. How does an ohmmeter measure resistance?
6. Where are the limits of linearity in real resistors?
7. What examples are there of linear and non-linear resistors?
8. What else can the resistance depend on?



From:

<https://mexle.te.hs-heilbronn.de/> - **MEXLE Wiki**

Permanent link:

[https://mexle.te.hs-heilbronn.de/lab\\_electrical\\_engineering/1\\_resistors?rev=1773110329](https://mexle.te.hs-heilbronn.de/lab_electrical_engineering/1_resistors?rev=1773110329)



Last update: **2026/03/10 03:38**