

Exam Summer Semester 2024

Student Group

First Name	Surname	Matrikel Nr.

Table of Contents

Exam Summer Semester 2024	2
Additional permitted Aids	2
Hits	2
Tasks	2
Exercise E2 Electrostatics I (written test, approx. 8 % of a 120-minute written test, SS2024)	2
Exercise E1 Electrostatics II (written test, approx. 10 % of a 120-minute written test, SS2024)	4
Exercise E1 Capacitor (written test, approx. 12 % of a 120-minute written test, SS2024)	5
Exercise E1 Magnetic Field Lines (written test, approx. 6 % of a 120-minute written test, SS2024)	5
Exercise E6 Fields of an coax Cable (written test, approx. 12 % of a 120-minute written test, SS2024)	7
Exercise E8 Lorentz Force (written test, approx. 8 % of a 120-minute written test, SS2024)	9
Exercise E10 Magnetic Potential (written test, approx. 8 % of a 120-minute written test, SS2024)	10
Exercise E12 Self-Induction (written test, approx. 8 % of a 120-minute written test, SS2024)	11
Exercise E14 Magnetic Circuit (written test, approx. 9 % of a 120-minute written test, SS2024)	11
Exercise E16 Magnetic Circuit (written test, approx. 10 % of a 120-minute written test, SS2024)	13
Exercise E18 Magnetic Circuit (written test, approx. 10 % of a 120-minute written test, SS2024)	15

Exam Summer Semester 2024

Additional permitted Aids

- non-programmable calculator,
- formulary (4 one-sided DIN A4 pages)

Hits

- The duration of the exam is 120 min.
- Attempts to cheat will lead to exclusion and failure of the exam.
- Withdrawal is no longer possible after these exam has been handed out.
- Please write down intermediate calculations and results on the assignment sheet. (when more space is needed also on the reverse side. In this case: Mark it clearly).
- Always use units in the calculation.
- Use a document-proof, non-red pen.

Tasks

Exercise E2 Electrostatics I

(written test, approx. 8 % of a 120-minute written test, SS2024)

Given is the arrangement of the charges as in the picture below. The values of the point charges are $q_1 = 1 \text{ nC}$, $q_2 = 1 \text{ nC}$, $q_3 = 1 \text{ nC}$, $q_4 = 1 \text{ nC}$, $q_5 = 1 \text{ nC}$. Which value needs E_4 to have to get a resulting force of 0 N on q_0 ?

Path: $q_0 = -1 \text{ nC}$

- $q_1 = -5 \text{ nC}$

Path: $E_4 = 2500 \text{ V/m}$

$$\vec{F}_{01} = \left(\begin{array}{c} +917 \\ \sim \mu \text{N} \end{array} \right) \parallel 0$$

In the beginning the are 5 force components, we can not calculate the resulting magnitude of the force.

$$|\vec{F}_{01}| = \sqrt{F_{01,x}^2 + F_{01,y}^2} = \sqrt{(917 \cdot 10^{-6})^2 + (917 \cdot 10^{-6})^2} = 1294 \cdot 10^{-6} \text{ N} = 1.294 \text{ nN}$$

$$|\vec{F}_{02}| = \sqrt{F_{02,x}^2 + F_{02,y}^2} = \sqrt{(917 \cdot 10^{-6})^2 + (917 \cdot 10^{-6})^2} = 1294 \cdot 10^{-6} \text{ N} = 1.294 \text{ nN}$$

$$|\vec{F}_{03}| = \sqrt{F_{03,x}^2 + F_{03,y}^2} = \sqrt{(917 \cdot 10^{-6})^2 + (917 \cdot 10^{-6})^2} = 1294 \cdot 10^{-6} \text{ N} = 1.294 \text{ nN}$$

$$|\vec{F}_{04}| = \sqrt{F_{04,x}^2 + F_{04,y}^2} = \sqrt{(917 \cdot 10^{-6})^2 + (917 \cdot 10^{-6})^2} = 1294 \cdot 10^{-6} \text{ N} = 1.294 \text{ nN}$$

$$|\vec{F}_{05}| = \sqrt{F_{05,x}^2 + F_{05,y}^2} = \sqrt{(917 \cdot 10^{-6})^2 + (917 \cdot 10^{-6})^2} = 1294 \cdot 10^{-6} \text{ N} = 1.294 \text{ nN}$$

$$|\vec{F}_{00}| = \sqrt{F_{00,x}^2 + F_{00,y}^2} = \sqrt{(917 \cdot 10^{-6})^2 + (917 \cdot 10^{-6})^2} = 1294 \cdot 10^{-6} \text{ N} = 1.294 \text{ nN}$$

$$\frac{|\vec{F}_{01}|}{|q_0|} = \frac{1.294 \cdot 10^{-6} \text{ N}}{1 \cdot 10^{-9} \text{ C}} = 1294 \cdot 10^3 \text{ V/m} = 1.294 \text{ kV/m}$$

$$\frac{|\vec{F}_{02}|}{|q_0|} = \frac{1.294 \cdot 10^{-6} \text{ N}}{1 \cdot 10^{-9} \text{ C}} = 1294 \cdot 10^3 \text{ V/m} = 1.294 \text{ kV/m}$$

$$\frac{|\vec{F}_{03}|}{|q_0|} = \frac{1.294 \cdot 10^{-6} \text{ N}}{1 \cdot 10^{-9} \text{ C}} = 1294 \cdot 10^3 \text{ V/m} = 1.294 \text{ kV/m}$$

$$\frac{|\vec{F}_{04}|}{|q_0|} = \frac{1.294 \cdot 10^{-6} \text{ N}}{1 \cdot 10^{-9} \text{ C}} = 1294 \cdot 10^3 \text{ V/m} = 1.294 \text{ kV/m}$$

$$\frac{|\vec{F}_{05}|}{|q_0|} = \frac{1.294 \cdot 10^{-6} \text{ N}}{1 \cdot 10^{-9} \text{ C}} = 1294 \cdot 10^3 \text{ V/m} = 1.294 \text{ kV/m}$$

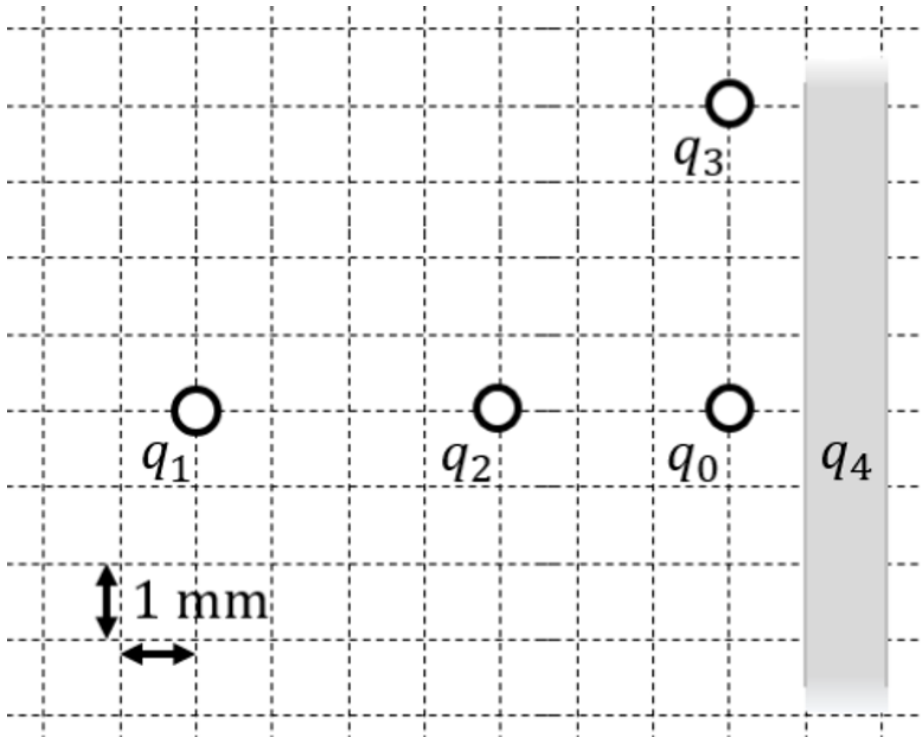

1. Calculate the single forces \vec{F}_{01} , \vec{F}_{02} , \vec{F}_{03} , on the charge q_0 !

Path

First, set up a coordinate system. Here, I choose x pointing to the right (positive values to the right) and y pointing upwards (positive values upwards).

Then, calculate the magnitude of the forces, like \vec{F}_{01} (force on q_0 from q_1).

The force \vec{F}_{01} is purely on the x -axis and therefore equal to $F_{01,x}$.
$$\vec{F}_{01} = F_{01,x} \hat{x} = \frac{1}{4\pi\epsilon_0} \cdot \frac{q_1 q_0}{r_{01}^2} \hat{x} = \frac{1}{4\pi \cdot 8.854 \cdot 10^{-12} \text{ As/Vm}} \cdot \frac{1 \cdot 10^{-9} \text{ C} \cdot 5 \cdot 10^{-9} \text{ C}}{(7 \cdot 10^{-3} \text{ m})^2} \hat{x} = 917. \dots \cdot 10^{-6} \frac{\text{As}^2 \cdot \text{Vm}}{\text{As} \cdot \text{m}^2} = 917. \dots \cdot 10^{-6} \frac{\text{VA}}{\text{m}} = 917. \dots \cdot 10^{-6} \frac{\text{Ws}}{\text{m}} \hat{x} = +917. \dots \mu\text{N} \hat{x}$$
 Since both q_0 and q_1 have the same sign for their charges, they are repelling each other. Therefore, The force \vec{F}_{01} points to the right (positive value).

Similarly, we get for \vec{F}_{02} and \vec{F}_{03}
$$\vec{F}_{02} = F_{02,x} \hat{x} = -1123. \dots \mu\text{N} \hat{x} \quad \vec{F}_{03} = F_{03,y} \hat{y} = -1123. \dots \mu\text{N} \hat{y}$$
 Since q_0 and q_2 have the different sign for their charges, they are attract each other. Therefore, The force \vec{F}_{02} points to the left (negative value).

Since q_0 and q_3 have the different sign for their charges, they are attract each other. Therefore, The force \vec{F}_{03} points downwards (negative value).

Exercise E1 Electrostatics II

(written test, approx. 10 % of a 120-minute written test, SS2024)

You must analyze an aluminum profile for usage in an environment critical for electrostatic discharge.

The figure on the right shows the cross-section of the aluminum element (hatched). During the application, it might get charged up. All areas in white consist of air (= dielectric).

Six designated areas are shown by dashed frames and numbers n, which are partly inside the object.

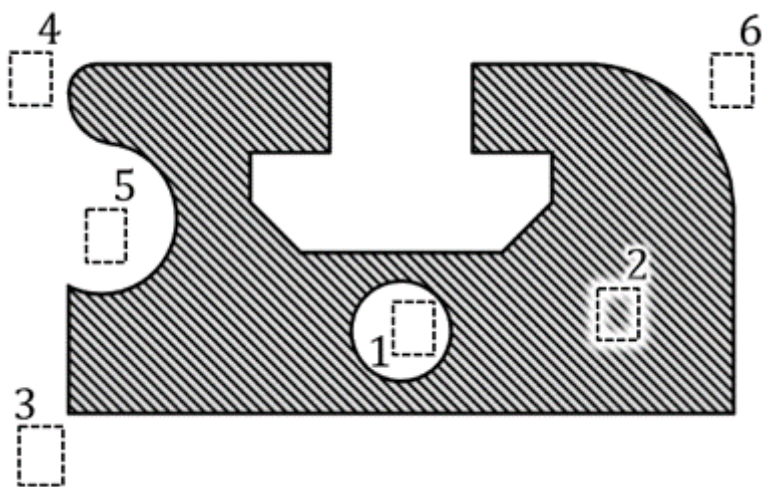
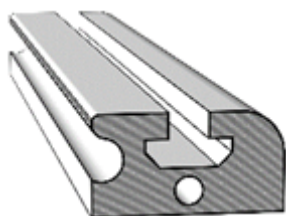

Arrange the designated areas clearly according to ascending field strengths $|\vec{E}_n|$ (absolute magnitude)! Indicate also, if designated areas have quantitatively the same field strength.

Result

$$|E_1|=|E_2|=0 < |E_5| < |E_6| < |E_4| < |E_3|$$

(written test, approx. 6 % of a 120-minute written test, SS2024)

The following setup illustrates how a permanent magnet affects the H-field, based on the fundamental definition of the H-field.

- Four conductors are located perpendicular to the plane of the diagram

Result: All of them conduct a current with the same magnitude, but not in the same direction.

- A permanent magnet is located in between the conductors.

- The H-field is defined by currents $\sum I = \int H \{ \text{r m d} \} s$.
- In the permanent magnet, there are no free currents.
- The bound currents (of the permanent magnet) create also an H field.
- This exits on the north pole and enters the magnet on the south pole (similar to the B-field)_
- $H = B/\mu_0$
- The H-field from task 1 gets distracted

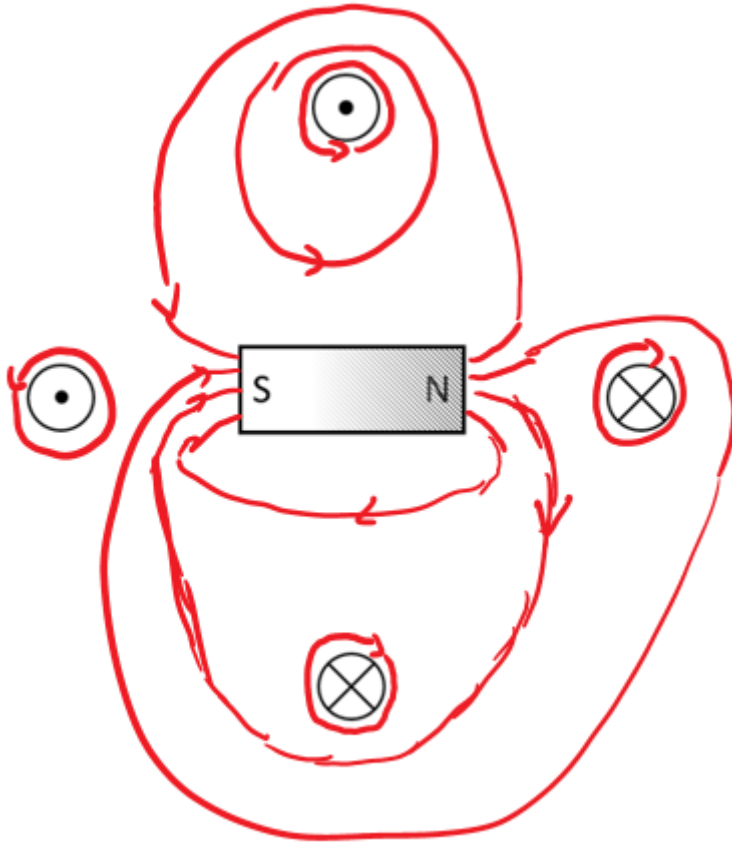

st 10 field lines of the H-field
and density for the shown

.. D
qua
are:
Res

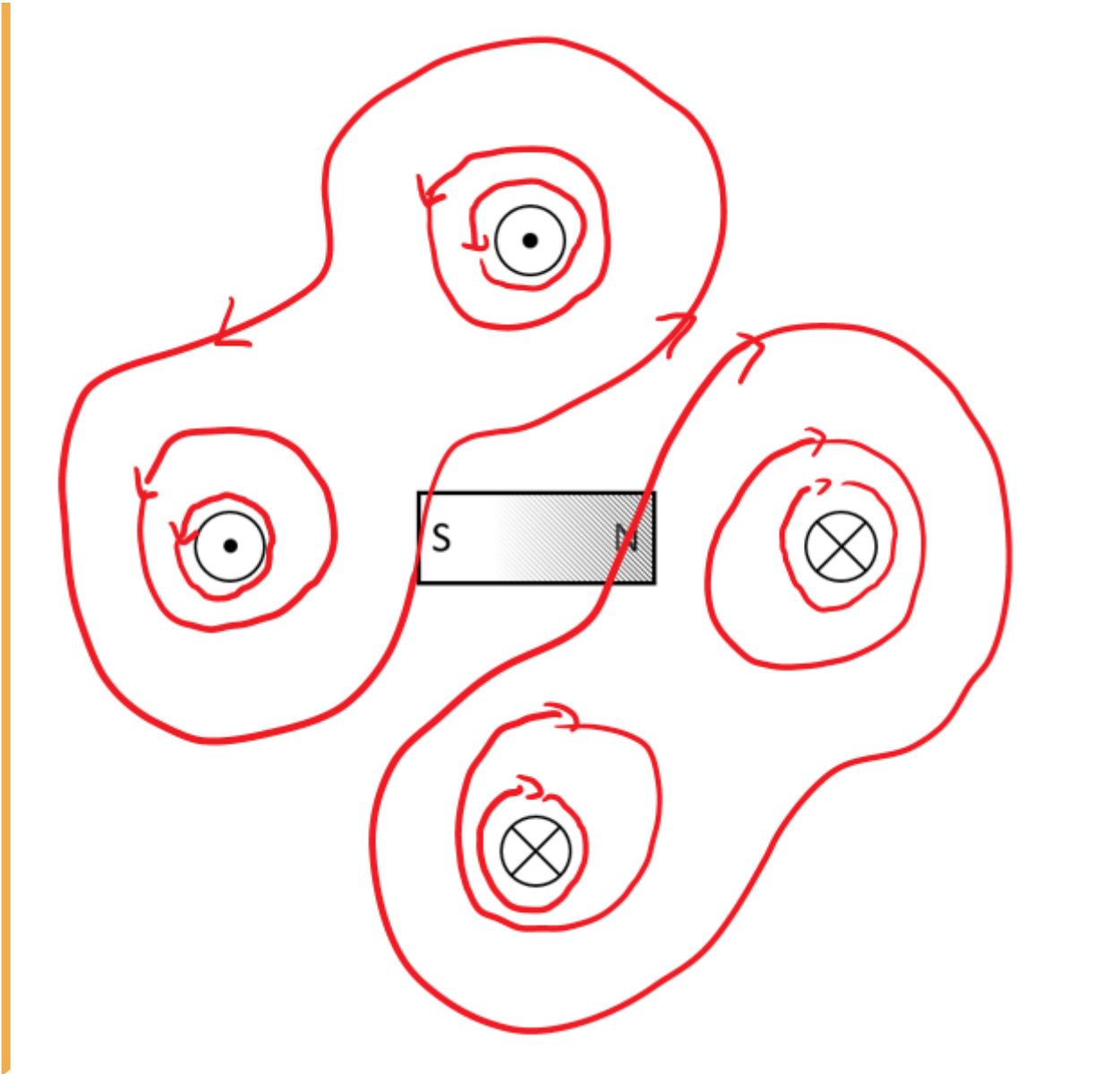

Exercise E6 Fields of an coax Cable
 (written test, approx. 12 % of a 120-minute written test, SS2024)

2. Plot the graph of the magnitude of the electric field E and the magnetic field B . The diagram shows the cross-section of a coaxial cable with the origin $r=0$ in the center of the inner conductor. The diagram is labeled as follows:

path • Inner conductor: $+3.3 \text{ mA}$, $+10 \text{ nC}$ (current into the plane of the path diagram)

path • Outer conductor: -3.3 mA , 0 nC (current out of the plane of diagram)

- for $(0.1 \text{ mm} | 0)$: $E_{\text{in}} = 328 \text{ V/m}$
- for $(0.55 \text{ mm} | 0)$: $E_{\text{out}} = 0.985 \text{ V/m}$

The magnitude of the electric displacement field D can be calculated by: $\int D \cdot dA = Q$.

Here, for any position radial to the center, the surrounding area is the surface of a cylindrical shape (here for simplicity without the round endings).

• In general, the E -field is proportional to $\frac{1}{r}$ for the situation between both conductors.

• For the charges Q within the surface of the conductor, there is no D -field within the conductor. within a circle with the radius s .

$\propto x)$ is proportional to the area within this radius. Therefore, The formula $H = \frac{I}{2 \pi \cdot r}$ gets $H(x) = \frac{I}{2 \pi \cdot x} \cdot \pi \cdot x^2$.
 So, we get for D_{in} at $(0.1 \text{ mm} | 0)$, D_{out} at $(0.55 \text{ mm} | 0)$ and D_{out} at $(0.55 \text{ mm} | 0)$ within the outer conductor one also gets a linear proportionality with a similar approach.

$$D_{\text{in}} = \frac{Q}{2 \pi \cdot r_{\text{in}} \cdot l} = \frac{10 \cdot 10^{-9} \text{ C}}{2 \pi \cdot \{0.1 \cdot 10^{-3} \text{ m}\} \cdot 0.5 \text{ m}}$$

$$D_{\text{out}} = \frac{Q}{2 \pi \cdot r_{\text{out}} \cdot l} = \frac{10 \cdot 10^{-9} \text{ C}}{2 \pi \cdot \{0.55 \cdot 10^{-3} \text{ m}\} \cdot 0.5 \text{ m}}$$

Hint: For the direction, one has to consider the sign of the enclosed charge. By this, we see that the D -field is positive.
 But here, again only the magnitude was questioned!

.. What is the magnitude of the magnetic field strength H at $(0.1 \text{ mm} | 0)$ and $(0.55 \text{ mm} | 0)$?

Path

The magnitude of the magnetic field strength H can be calculated by: $H = \frac{I}{2 \pi \cdot r}$
 So, we get for H_{in} at $(0.1 \text{ mm} | 0)$, and H_{out} at $(0.55 \text{ mm} | 0)$:

$$H_{\text{in}} = \frac{I}{2 \pi \cdot r_{\text{in}}} = \frac{+3.3 \text{ A}}{2 \pi \cdot \{0.1 \cdot 10^{-3} \text{ m}\}}$$

$$H_{\text{out}} = \frac{I}{2 \pi \cdot r_{\text{out}}} = \frac{+3.3 \text{ A}}{2 \pi \cdot \{0.55 \cdot 10^{-3} \text{ m}\}}$$

Hint: For the direction, one has to consider the right-hand rule. By this, we see that the H -field on the right side points downwards.
 Therefore, the sign of the H -field is negative.
 But here, only the magnitude was questioned!

Exercise E8 Lorentz Force
(written test, approx. 8 % of a 120-minute written test, SS2024)

2. Consider the system of the lift drive, that consists of a homogeneous shorted field of fixed floor and a pair of coils resulting from the magnet on the mobile shuttle (see image).

Result

Path

Since the result of \vec{F}_L has to be perpendicular to \vec{B} -field and conductor, the force has to point to the left or the right.

For a homogeneous \vec{B} -field ("constant magnetic field of the shuttle"), the Lorentz forces cancel each other out.

The Lorentz force can only have a lifting effect in an inhomogeneous field.

In this case, the sum of the forces results in a repulsing force, see image.

Beside boundary effects, the field gets also inhomogeneous, by the additional field of

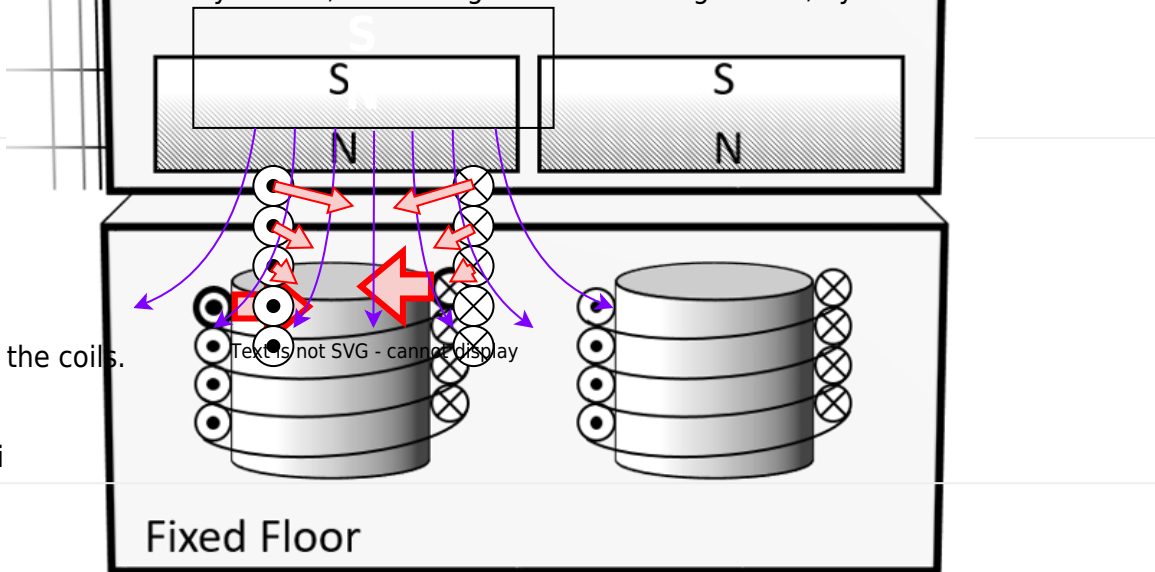

- current $I = 1.6 \text{ A}$
- magnetic field of the shuttle is homogeneous with $B = 0.5 \text{ T}$

1. Calculate the magnitude of the resulting force on one coil!

Path

The Lorentz force on a conductor the length l and the current I in a \vec{B} -field is

$$|\vec{F}_L| = I \cdot l \cdot B \cdot \cos(\angle \vec{B}, \vec{l})$$

$$= I \cdot (N \cdot 2\pi r) \cdot B \cdot \cos(\angle \vec{B}, \vec{l})$$

$$= 1.6 \text{ A} \cdot (500 \cdot 2\pi \cdot 40 \cdot 10^{-3} \text{ m}) \cdot 0.5 \text{ T} \cdot \cos 90^\circ$$

Exercise E10 Magnetic Potential**(written test, approx. 8 % of a 120-minute written test, SS2024)**

Calculate the magnetic potential difference V_{m} for the following paths as shown by the solid lines.

Dotted lines are only for there for symmetry aspects!

The wires conduct the following currents:

- $|I_1| = 2 \text{ A}$
- $|I_2| = 5 \text{ A}$
- $|I_3| = 11 \text{ A}$
- $|I_4| = 7 \text{ A}$

Pay attention to the signs of the currents (given by the diagrams) and of the results!

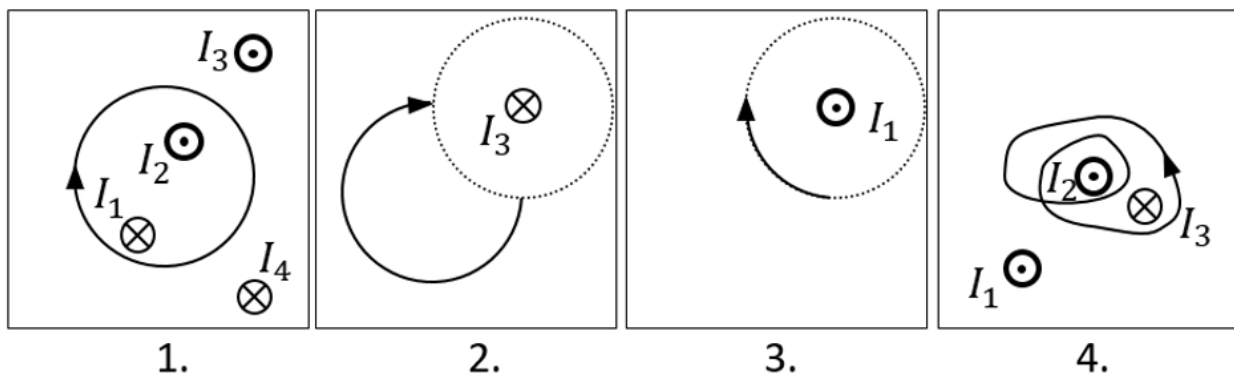

Result

Based on the right-hand rule and the part of a full revolution the following results:

1. Task: $+I_1 - I_2 = -3 \text{ A}$
2. Task: $+\frac{1}{4} I_3 = \frac{11}{4} \text{ A}$ (it does not matter which way the path goes from the startpoint to the endpoint, as long as it has the same direction and number of revolutions)
3. Task: $-\frac{1}{4} I_1 = -0.5 \text{ A}$
4. Task: $+2 \cdot I_2 - 1 \cdot I_3 = -1 \text{ A}$

Exercise E12 Self-Induction

(written test, approx. 8 % of a 120-minute written test, SS2024)

2. Determine the height of a 30 volt generator coil radius of 12 cm generator has 500 turns.
 Result: Current through the coil changes linearly from 0 A to 3 A in 0.02 ms.
 The arrangement is located in air ($\mu_r=1$).
 Path

$\mu_0 = 4\pi \cdot 10^{-7} \text{ Vs/Am}$ $U = 30 \text{ V}$
<p>.. Calculate the (self-)inductance of the coil. For the linear change of the current the formula of the induced voltage can also be linearized: $u_{\text{ind}} = -L \cdot \frac{di}{dt} \quad \parallel \quad u_{\text{ind}} = -L \cdot \frac{\Delta i}{\Delta t} \quad \parallel \quad -1.32 \cdot 10^{-3} \cdot \frac{3 \text{ A}}{0.02 \cdot 10^{-3} \text{ s}}$</p>
<p>The formula for the induction of a long coil is: $L = \mu_0 \mu_r \cdot N^2 \cdot \frac{A}{l} = 4\pi \cdot 10^{-7} \cdot (500)^2 \cdot \frac{\pi \cdot (2 \cdot 10^{-2})^2}{2 \cdot 10^{-2}}$</p>

Exercise E14 Magnetic Circuit

(written test, approx. 9 % of a 120-minute written test, SS2024)

1. Calculate the resulting magnetic field in the cross-sectional area of $A=300 \text{ mm}^2$ with an average circumference of $l=3 \text{ dm}$.

Path

$R_{\text{m}} = \frac{l}{\mu_0 \mu_r N^2 A}$
<p>First we have to calculate the magnetic resistance in a region $\mu_r=1$ based on the sources: $R_{\text{m}} = \frac{l}{\mu_0 \mu_r N^2 A} = \frac{3 \cdot 10^{-1} \text{ m}}{4\pi \cdot 10^{-7} \text{ Vs/Am} \cdot (1)^2 \cdot (300 \cdot 10^{-6} \text{ m}^2)} = 3884193 \text{ Vs/Am}$</p>
<p>To get the flux Φ, the Hopkinson's Law can be applied - similar to the Ohm's Law: $\Phi = \frac{I}{R_{\text{m}}} = \frac{60 \text{ A}}{3884193 \text{ Vs/Am}} = 1.54 \cdot 10^{-5} \text{ Wb}$</p>
<p>$B = \frac{\Phi}{A} = \frac{1.54 \cdot 10^{-5} \text{ Wb}}{300 \cdot 10^{-6} \text{ m}^2} = 51.3 \text{ T}$</p>

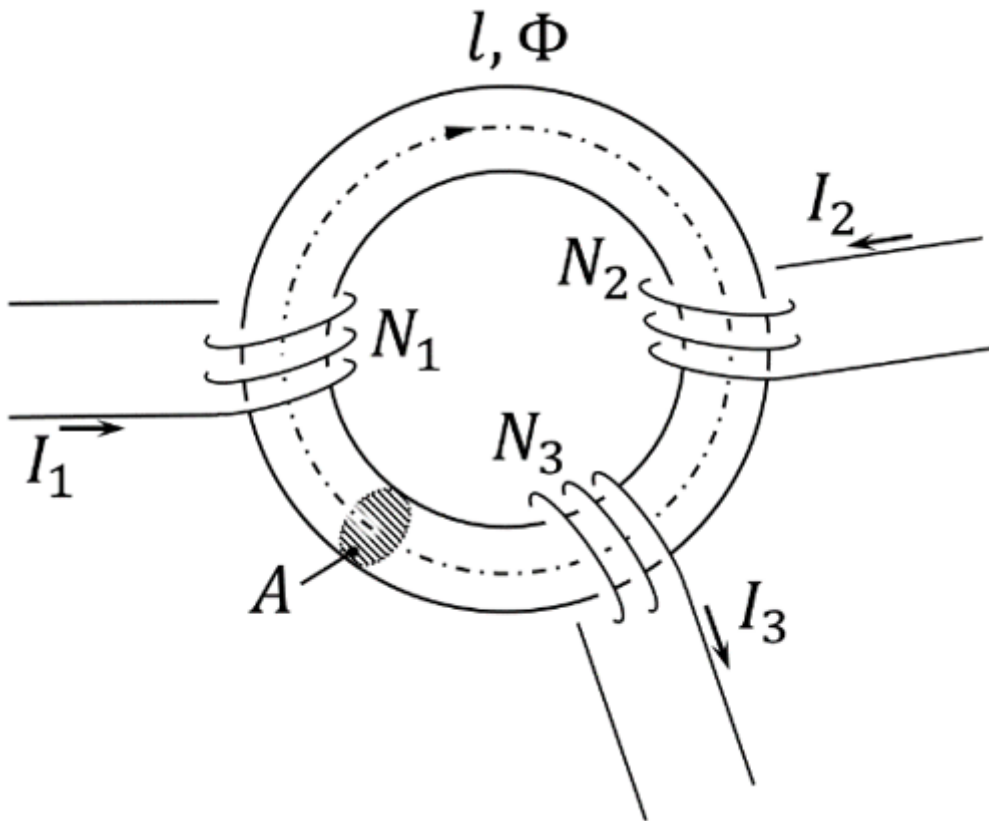

On the core, there are three coils with:

- Coil 1: $N_1 = 1200$, $I_1 = 100 \text{ mA}$
- Coil 2: $N_2 = 33$, $I_2 = 3 \text{ A}$
- Coil 3: $N_3 = 270$, $I_3 = 0.3 \text{ A}$

Refer to the drawing for the direction of the windings, current, and flux!

1. Draw the equivalent magnetic circuit that fully represents the setup. Name all the necessary magnetic resistances, fluxes, and voltages.

Result

- Since the material, and diameter of the core is constant, one can directly simplify the magnetic resistor into a single R_m .
- For the orientation of the magnetic voltages θ_1 , θ_2 , and θ_3 , the orientation of the coils and the direction of the current has to be taken into account by the right-hand rule.
- There is only one flux Φ
- The magnetic voltages are antiparallel to the flux for sources and parallel for the load.

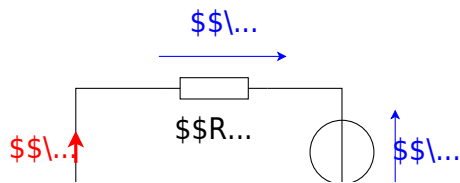

Exercise E16 Magnetic Circuit
(written test, approx. 10 % of a 120-minute written test, SS2024)

2. For a sinusoidal voltage U_C and a current I_C in the circuit, with an equivalent series resistance R and an equivalent series capacitance C , in the shown circuit?

Path

- $U_C = 100 \text{ V}$
- $f = 29.7 \text{ MHz}$
- $|Z_{RLC}(f_r)| = 20.0 \text{ m}\Omega$

The formula for the resonance frequency f_r is:
$$f_r = \frac{1}{2\pi\sqrt{LC}}$$

 The voltage across the ideal capacitor is the input voltage by the Q -factor increased:

$$U_C = U_{in} \cdot Q = 100 \text{ V} \cdot 5 = 500 \text{ V}$$

 The input current I_C is $I_C = \frac{U_C}{|Z_{RLC}(f_r)|} = \frac{500 \text{ V}}{20.0 \text{ m}\Omega} = 25 \text{ A}$

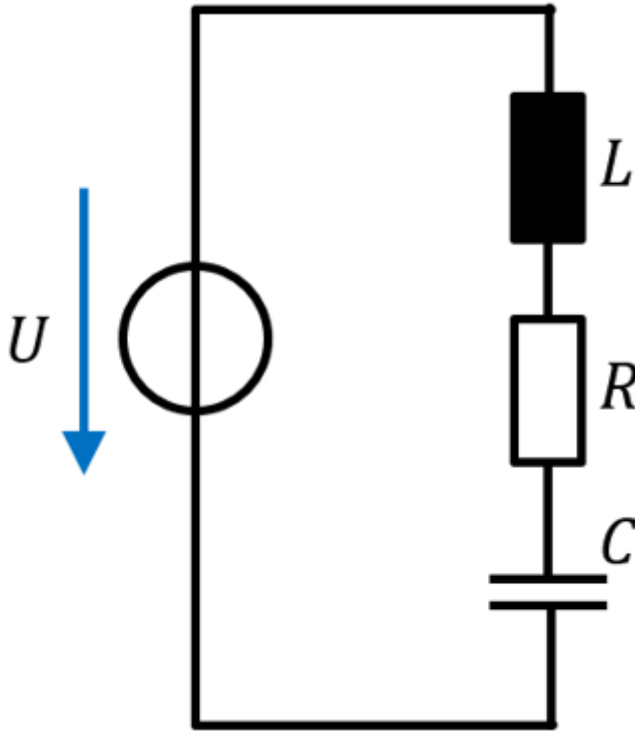

A given capacitor shall have the following values:

- $C=10 \text{ nF}$
- $R=20 \text{ m}\Omega$
- $L=1.6 \text{ nH}$

1. What is the impedance Z_{RLC} of this real capacitor for $f_0=44 \text{ MHz}$? (Phase and magnitude)

Path

The impedance is based on the resistance R and the reactance $X_{\text{LC}} = \text{j} \cdot (X_L - X_C)$:
$$\underline{Z}_{\text{RLC}} = R + \text{j} \cdot (X_L - X_C) = R + \text{j} \cdot (\omega L - \frac{1}{\omega C}) = R + \text{j} \cdot (2\pi f \cdot L - \frac{1}{2\pi f \cdot C})$$

The reactive part is
$$X_{\text{LC}} = 2\pi f \cdot L - \frac{1}{2\pi f \cdot C} = 2\pi \cdot 44 \cdot 10^6 \text{ MHz} \cdot 1.6 \cdot 10^{-9} \text{ nH} - \frac{1}{2\pi \cdot 44 \cdot 10^6 \text{ MHz} \cdot 10 \cdot 10^{-9} \text{ nF}} = +0.08062... \Omega$$

To get the magnitude of the impedance $|\underline{Z}_{\text{RLC}}|$ one can use the Pythagorean Theorem:
$$|\underline{Z}_{\text{RLC}}| = \sqrt{R^2 + X_{\text{LC}}^2} = \sqrt{(0.020 \Omega)^2 + (0.08062... \Omega)^2} = 0.0830... \Omega$$

For the phase φ the \arctan can be applied:
$$\varphi = \arctan \left(\frac{X_{\text{LC}}}{R} \right) = \arctan \left(\frac{0.08062...}{0.020} \right)$$

$$\sim\Omega\}\over{0.020 \sim\Omega\}} \right) \parallel \&= 1.3276 ... \hat{=} +76^\circ \parallel$$

Exercise E18 Magnetic Circuit
(written test, approx. 10 % of a 120-minute written test, SS2024)

2. Calculate and draw the apparent power, and the active and reactive power of the 400V / 50 Hz three-phase power net. Each single string has a resistor $R=5 \sim\Omega$ and an inductance of $L=10 \sim\text{mH}$.

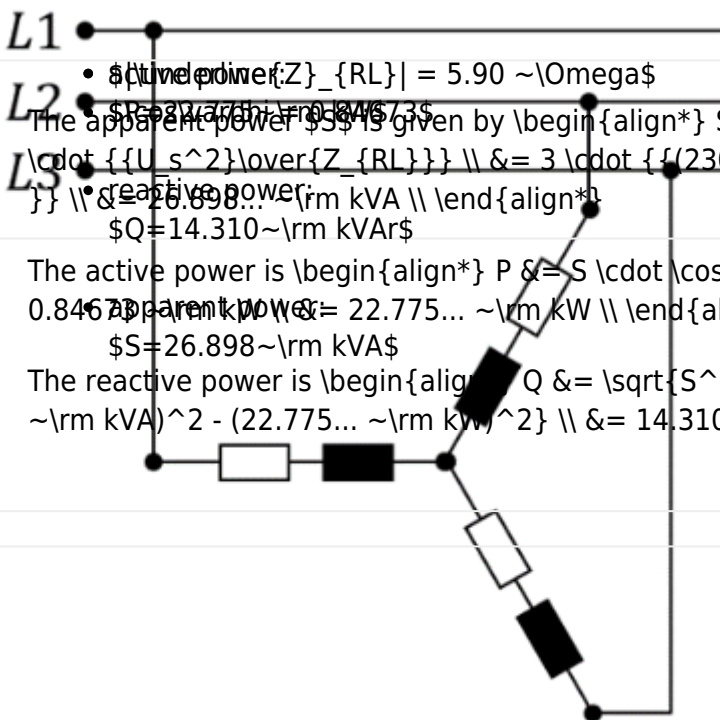

- $|Z_{RL}| = 5.90 \sim\Omega$
- $S = 26.898 \sim\text{kVA}$
- $P = 22.775 \sim\text{kW}$
- $Q = 14.310 \sim\text{kVAr}$

The apparent power S is given by
$$S = 3 \cdot U_s \cdot I_s = 3 \cdot \frac{U_s^2}{|Z_{RL}|} = 3 \cdot \frac{(230 \text{ V})^2}{5.90 \sim\Omega} = 26.898 \sim\text{kVA}$$

The active power is
$$P = S \cdot \cos \varphi = 26.898 \sim\text{kVA} \cdot 0.84673 = 22.775 \sim\text{kW}$$

The reactive power is
$$Q = \sqrt{S^2 - P^2} = \sqrt{(26.898 \sim\text{kVA})^2 - (22.775 \sim\text{kW})^2} = 14.310 \sim\text{kVAr}$$

1. Calculate the $\cos \varphi$, and the magnitude of the impedance $|Z|$ for a single string.

Path

The phase φ is given by:
$$\varphi = \arctan \left(\frac{X_L}{R} \right) = \arctan \left(\frac{2\pi \cdot f \cdot L}{R} \right) = \arctan \left(\frac{2\pi \cdot 50 \text{ Hz} \cdot 10 \cdot 10^{-3} \text{ H}}{5 \sim\Omega} \right) = 0.5609 ... \hat{=} +32^\circ$$

With this, the $\cos \varphi$ becomes
$$\cos \varphi = \cos(0.5609 ...) = 0.84673...$$

The impedance is given by:
$$\underline{Z}_{RL} = \sqrt{X_L^2 + R^2} = \sqrt{(2\pi \cdot f \cdot L)^2 + R^2} = \sqrt{(2\pi \cdot 50 \text{ Hz} \cdot 10 \cdot 10^{-3} \text{ H})^2 + (5 \Omega)^2} = 5.905... \Omega$$

From:

<https://mexle.te.hs-heilbronn.de/> - MEXLE Wiki

Permanent link:

https://mexle.te.hs-heilbronn.de/electrical_engineering_and_electronics_1/ss2024_exam?rev=1768172348

Last update: 2026/01/11 23:59

