

Exam Summer Semester 2022

Student Group

First Name	Surname	Matrikel Nr.

Table of Contents

Exam Summer Semester 2022 2

 Additional permitted Aids 2

 Hits 2

 Tasks 2

 Exercise E1 Electrostatics I (written test, approx. 10 % of a 120-minute written test, SS2022) 2

 Exercise E2 Electrostatics II (written test, approx. 10 % of a 120-minute written test, SS2022) 4

 Exercise E4 Electron Velocity in Semiconductors (written test, approx. 6 % of a 120-minute written test, SS2022) 4

 Exercise E2 Capacitor (written test, approx. 7 % of a 120-minute written test, SS2022) 5

 Exercise E7 Magnetic Circuit (written test, approx. 7 % of a 120-minute written test, SS2022) 7

 Exercise E9 Self Induction (written test, approx. 8 % of a 120-minute written test, SS2022) 8

 Exercise E10 Series Resonant Circuit (written test, approx. 10 % of a 120-minute written test, SS2022) 9

Exam Summer Semester 2022

Here is only a part of the exam in more details given.

The full results can be found in [ILIAS](#)

Additional permitted Aids

- non-programmable calculator,
- formulary (4 one-sided DIN A4 pages)

Hits

- The duration of the exam is 120 min.
- Attempts to cheat will lead to exclusion and failure of the exam.
- Withdrawal is no longer possible after these exam has been handed out.
- Please write down intermediate calculations and results on the assignment sheet. (when more space is needed also on the reverse side. In this case: Mark it clearly).
- Always use units in the calculation.
- Use a document-proof, non-red pen.

Tasks

Exercise E1 Electrostatics I

(written test, approx. 10 % of a 120-minute written test, SS2022)

2. Which two charges q_1 and q_2 are distributed on the two spheres of radius a and b respectively. The value of the point charge q_0 is $q_0 = -1 \cdot 10^{-9} \text{ C}$. Which value needs E_4 to have to get a resulting force of 0 N on q_0 ?

Path: $q_0 = -1 \cdot 10^{-9} \text{ C}$

- $q_1 = -2 \cdot 10^{-9} \text{ C}$

Path: $E_4 = 2310.97 \text{ V/m}$

$$\vec{F}_{01} = \left(\begin{array}{c} 19.97 \\ 0 \\ 0 \end{array} \right) \cdot 10^{-6} \text{ N}$$

In the x -direction the two charges q_1 and q_2 are distributed. We cannot calculate the resulting magnitude of the force F_{01} in the x -direction.

$$F_{01} = \frac{1}{4\pi\epsilon_0} \cdot \frac{q_0 \cdot q_1}{r^2} = \frac{1}{4\pi \cdot 8.854 \cdot 10^{-12} \text{ As/Vm}} \cdot \frac{(-1 \cdot 10^{-9} \text{ C}) \cdot (-2 \cdot 10^{-9} \text{ C})}{(0.1 \text{ m})^2} = 19.97 \cdot 10^{-6} \text{ N}$$

$$F_{02} = \frac{1}{4\pi\epsilon_0} \cdot \frac{q_0 \cdot q_2}{r^2} = \frac{1}{4\pi \cdot 8.854 \cdot 10^{-12} \text{ As/Vm}} \cdot \frac{(-1 \cdot 10^{-9} \text{ C}) \cdot (-2 \cdot 10^{-9} \text{ C})}{(0.1 \text{ m})^2} = 19.97 \cdot 10^{-6} \text{ N}$$

$$F_{03} = \frac{1}{4\pi\epsilon_0} \cdot \frac{q_0 \cdot q_3}{r^2} = \frac{1}{4\pi \cdot 8.854 \cdot 10^{-12} \text{ As/Vm}} \cdot \frac{(-1 \cdot 10^{-9} \text{ C}) \cdot (-2 \cdot 10^{-9} \text{ C})}{(0.1 \text{ m})^2} = 19.97 \cdot 10^{-6} \text{ N}$$

$$F_{04} = \frac{1}{4\pi\epsilon_0} \cdot \frac{q_0 \cdot q_4}{r^2} = \frac{1}{4\pi \cdot 8.854 \cdot 10^{-12} \text{ As/Vm}} \cdot \frac{(-1 \cdot 10^{-9} \text{ C}) \cdot (-2 \cdot 10^{-9} \text{ C})}{(0.1 \text{ m})^2} = 19.97 \cdot 10^{-6} \text{ N}$$

$$F_{05} = \frac{1}{4\pi\epsilon_0} \cdot \frac{q_0 \cdot q_5}{r^2} = \frac{1}{4\pi \cdot 8.854 \cdot 10^{-12} \text{ As/Vm}} \cdot \frac{(-1 \cdot 10^{-9} \text{ C}) \cdot (-2 \cdot 10^{-9} \text{ C})}{(0.1 \text{ m})^2} = 19.97 \cdot 10^{-6} \text{ N}$$

$$F_{06} = \frac{1}{4\pi\epsilon_0} \cdot \frac{q_0 \cdot q_6}{r^2} = \frac{1}{4\pi \cdot 8.854 \cdot 10^{-12} \text{ As/Vm}} \cdot \frac{(-1 \cdot 10^{-9} \text{ C}) \cdot (-2 \cdot 10^{-9} \text{ C})}{(0.1 \text{ m})^2} = 19.97 \cdot 10^{-6} \text{ N}$$

$$F_{07} = \frac{1}{4\pi\epsilon_0} \cdot \frac{q_0 \cdot q_7}{r^2} = \frac{1}{4\pi \cdot 8.854 \cdot 10^{-12} \text{ As/Vm}} \cdot \frac{(-1 \cdot 10^{-9} \text{ C}) \cdot (-2 \cdot 10^{-9} \text{ C})}{(0.1 \text{ m})^2} = 19.97 \cdot 10^{-6} \text{ N}$$

$$F_{08} = \frac{1}{4\pi\epsilon_0} \cdot \frac{q_0 \cdot q_8}{r^2} = \frac{1}{4\pi \cdot 8.854 \cdot 10^{-12} \text{ As/Vm}} \cdot \frac{(-1 \cdot 10^{-9} \text{ C}) \cdot (-2 \cdot 10^{-9} \text{ C})}{(0.1 \text{ m})^2} = 19.97 \cdot 10^{-6} \text{ N}$$

$$F_{09} = \frac{1}{4\pi\epsilon_0} \cdot \frac{q_0 \cdot q_9}{r^2} = \frac{1}{4\pi \cdot 8.854 \cdot 10^{-12} \text{ As/Vm}} \cdot \frac{(-1 \cdot 10^{-9} \text{ C}) \cdot (-2 \cdot 10^{-9} \text{ C})}{(0.1 \text{ m})^2} = 19.97 \cdot 10^{-6} \text{ N}$$

$$F_{10} = \frac{1}{4\pi\epsilon_0} \cdot \frac{q_0 \cdot q_{10}}{r^2} = \frac{1}{4\pi \cdot 8.854 \cdot 10^{-12} \text{ As/Vm}} \cdot \frac{(-1 \cdot 10^{-9} \text{ C}) \cdot (-2 \cdot 10^{-9} \text{ C})}{(0.1 \text{ m})^2} = 19.97 \cdot 10^{-6} \text{ N}$$

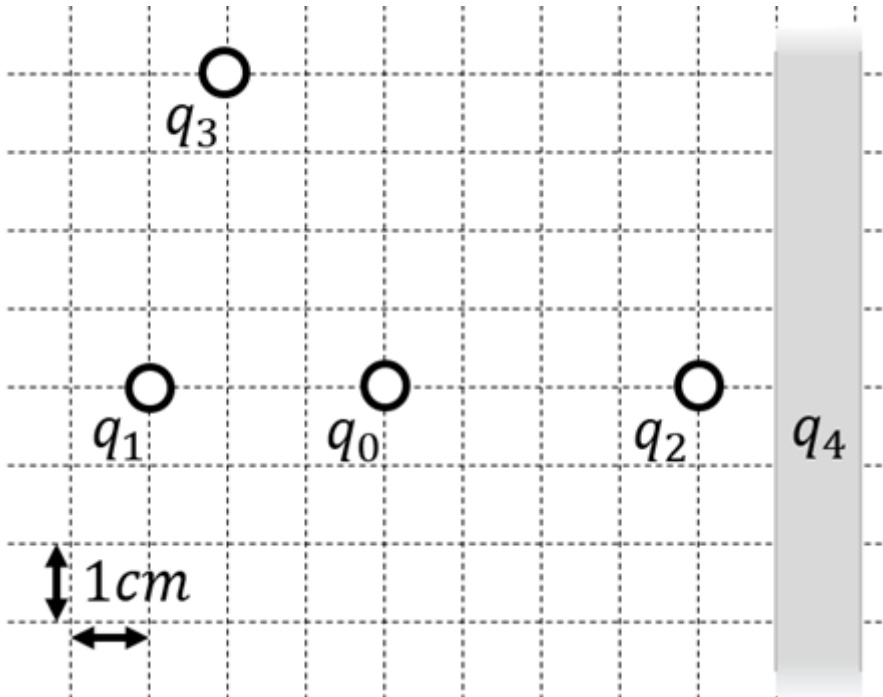

1. Calculate the single forces \vec{F}_{01} , \vec{F}_{02} , \vec{F}_{03} , on the charge q_0 !

Path

First, calculate the magnitude of the forces, like \vec{F}_{01} .

The force \vec{F}_{01} is purely on the x -axis and therefore equal to

$$\begin{aligned} F_{01,x} &= \frac{1}{4\pi\epsilon_0} \cdot \frac{q_1 \cdot q_0}{r_{01}^2} \\ &= \frac{1}{4\pi \cdot 8.854 \cdot 10^{-12} \text{ As/Vm}} \cdot \frac{1 \cdot 10^{-9} \text{ C} \cdot 2 \cdot 10^{-9} \text{ C}}{(3 \cdot 10^{-2} \text{ m})^2} \\ &= 19.97... \cdot 10^{-6} \frac{\text{As}^2 \cdot \text{Vm}}{\text{As} \cdot \text{m}^2} = 19.97... \cdot 10^{-6} \frac{\text{VA}}{\text{m}} \\ &= 19.97... \mu\text{N} \quad \text{(to the right)} \end{aligned}$$

Similarly, we get for \vec{F}_{02} and \vec{F}_{03}

$$\begin{aligned} \vec{F}_{02} &= F_{02,x} = -28.09... \mu\text{N} \quad \text{(to the right)} \\ \vec{F}_{03} &= -22.47... \mu\text{N} \quad \text{(to the top left)} \end{aligned}$$

For \vec{F}_{03} , we have to calculate the x - and y -component.

This is possible, by using the angle α between the line through q_0 and q_3 and the positive x -axis (pointing to the right).

So, α has to be between 90° and 180° . It can be calculated by:

$$\begin{aligned} \alpha &= \arctan\left(\frac{-4 \text{ cm}}{+2 \text{ cm}}\right) = \pi - 1.1071... \\ &= 180^\circ - 63.4...^\circ = 116.6...^\circ \end{aligned}$$

Based on this, the x - and y -component is:

$$\begin{aligned} F_{03,x} &= |\vec{F}_{03}| \cdot \cos \alpha = 10.05... \mu\text{N} \quad \text{(to the left)} \\ F_{03,y} &= |\vec{F}_{03}| \cdot \sin \alpha = 20.10... \mu\text{N} \quad \text{(to the top)} \end{aligned}$$

```
top)} \\ \end{align*}
```

[electrical_engineering_and_electronics:task_dtoqvpvrbdtozfk_with_calculation](#)
[electrostatic](#), [field lines](#), [exam ee2 ss2022](#)

Exercise E2 Electrostatics II

(written test, approx. 10 % of a 120-minute written test, SS2022)

The figure below shows an arrangement of ideal metallic conductors (gray hatched) charged up to $q = +1 \text{ nC}$.

In white a dielectric (e.g. vacuum) is shown.

Several designated areas are shown by dashed frames and numbers x , which are partly inside the object.

Arrange the designated areas clearly according to ascending field strengths $|\vec{E}_x|$ (absolute magnitude)!

Indicate also, if designated areas have quantitatively the same field strength.

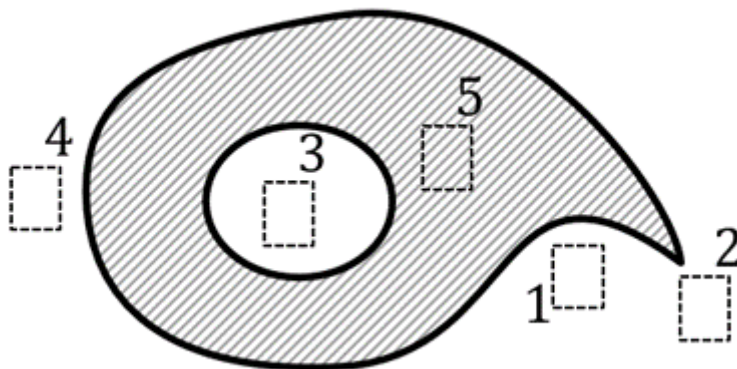

Result

$$|E_3| = |E_5| = 0 < |E_1| < |E_4| < |E_2|$$

[electrical_engineering_and_electronics:task_ic9pioiu0notvwfp_with_calculation](#)
[electrostatic](#), [electric field strength](#), [exam ee2 ss2022](#)

Exercise E4 Electron Velocity in Semiconductors

(written test, approx. 6 % of a 120-minute written test, SS2022)

A current of $I=1\text{ mA}$ flows through a cross-sectional area $A=10\text{ }\mu\text{m}^2$ in a semiconductor.

The electron density in the semiconductor is given by the number of dopant atoms per volume.

The doping shall provide 1 donator atom (= one electron) per 10^{10} silicon atoms. The molar volume of silicon is $V_{\text{mol,Si}} = 12\text{ }\mu\text{mol}^{-3}$, with $N_{\text{A}} = 6.022 \cdot 10^{23}$ silicon atoms per 1 mol .

The elementary charge is given as: $e_0 = 1.602 \cdot 10^{-19}\text{ As}$

What is the average electron velocity v_e in this semiconductor?

Path

The following formula gives the speed, where n_e is the number of electrons per volume.

$$v_e = \frac{I}{n_e \cdot e_0 \cdot A}$$

n_e can be derived from the overall number of Si-atoms per volume ($\frac{N_{\text{A}}}{V_{\text{mol,Si}}}$) and the fraction k_{Donators} of these atoms, which got substituted by donators.

$$n_e = \frac{N_{\text{A}}}{V_{\text{mol,Si}}} \cdot k_{\text{Donators}} \cdot e_0 \cdot A$$

Putting in the numbers:

$$v_e = \frac{1 \cdot 10^{-3}\text{ A}}{\frac{6.022 \cdot 10^{23}}{12 \cdot 10^{-6}\text{ m}^3/\text{mol}} \cdot 10^{-10} \cdot 1.602 \cdot 10^{-19}\text{ As} \cdot 10 \cdot (10^{-6}\text{ m})^2}$$

[electrical_engineering_and_electronics:task_tx86fewvysrcy8fc_with_calculation](#)
[electrostatic, electric field strength, exam ee2 ss2022](#)

Exercise E2 Capacitor

(written test, approx. 7 % of a 120-minute written test, SS2022)

Calculate the capacitance of a capacitor with the following dimensions: $\epsilon_0 = 8.85 \cdot 10^{-12}\text{ F/m}$ of air ($\epsilon_r = 1$), while the thickness of the dielectric material remains the same.

Length of layer: $l = 1.5\text{ mm}$

Distance between single layers: $d = 1.0\text{ }\mu\text{m}$

- Depth of component: $w = 0.7\text{ mm}$
- Number of layers (in the picture): 3 left-side and 3 right-side layers.

Path

The capacity can be derived from the geometry by: $C = \epsilon_0$

$\epsilon_r \frac{A}{d}$

The air bands another capacitor in series to the dielectric material. Therefore, the capacity can be calculated as $C_{\text{air}} = \epsilon_0 \frac{N \cdot A}{d}$

d

The capacity of air is $C_{\text{air}} = \epsilon_0 \frac{N \cdot A}{d} = 8.854 \cdot 10^{-12} \frac{\text{As/Vm}}{\text{m}} \cdot 5 \cdot \frac{1.5 \cdot 10^{-3} \cdot 0.7 \cdot 10^{-3}}{0.1 \cdot 10^{-6}} = 0.465 \text{ nF}$

By this the overall capacity is $C_{\text{c}} = 0.139 \text{ nF} \cdot 3 = 0.417 \text{ nF}$

For this, we have to count facing areas A_0 . There are $N=5$.

.. What is the field strength in the dielectric material between the layer, when a voltage of $U=6.3 \text{ V}$ is applied?

Path

The electric field strength E is given by: $E = \frac{U}{d} = \frac{6.3 \text{ V}}{1 \cdot 10^{-6} \text{ m}} = 6.3 \cdot 10^6 \text{ V/m}$

Therefore, the formula is $C = \epsilon_0 \epsilon_r \frac{N \cdot l \cdot w}{d} = 8.854 \cdot 10^{-12} \frac{\text{As/Vm}}{\text{m}} \cdot 3 \cdot \frac{5 \cdot 1.5 \cdot 10^{-3} \cdot 0.7 \cdot 10^{-3}}{1 \cdot 10^{-6}} = 0.417 \text{ nF}$

Exercise E7 Magnetic Circuit
(written test, approx. 7 % of a 120-minute written test, SS2022)

The magnetic setup below shall be given. Draw the equivalent magnetic circuit to represent the setup fully. Name all the necessary magnetic resistances, fluxes, and voltages. The components shall be designed in such a way, that the magnetic resistance is constant in it.

Formulas are not necessary.

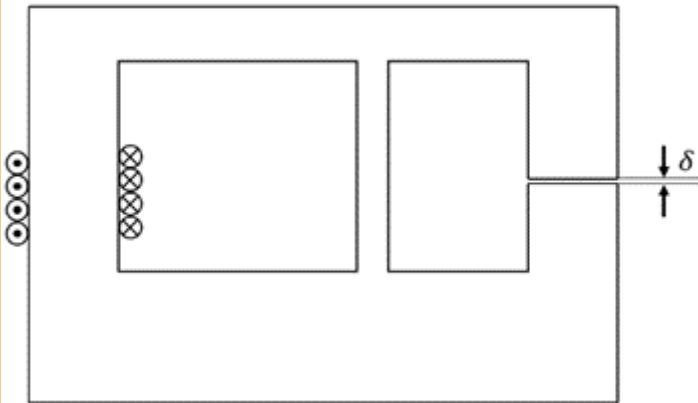

Path

Watch for parts of the magnetic circuit, where the width and material are constant. These parts represent the magnetic resistors which have to be calculated individually. Be aware, that every junction creates a branch with a new resistor, like for an electrical circuit - there must be a node on each "diversion".

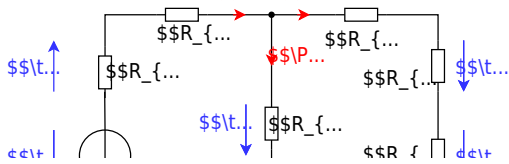
$$R_{\text{m}} = \frac{1}{\mu_0 \mu_r} \frac{l}{w \cdot h}$$

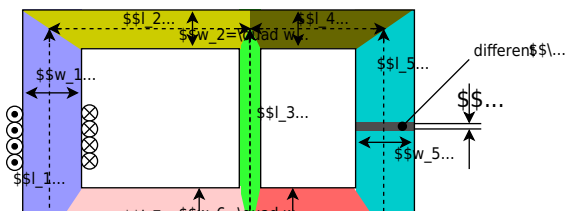

electrical_engineering_and_electronics:task_yp4rbdlj8kktyrhp_with_calculation
magnetic circuit, exam ee2 ss2022

Exercise E9 Self Induction
(written test, approx. 8 % of a 120-minute written test, SS2022)

2. A vertically rotating motor with a magnitude of the induced voltage $U_{ind}(t) = 3150 \cdot t$ V, which the circuit breaker has a DC voltage source $U_{DC} = 100$ V and a circuit breaker.

Sketch the breaker's circuit $i(t)$ and $u_{ind}(t) = 0$ with a percentage value of the induced current $i(t)$ induced linearly down to 0 A within $1 \mu s$.

(The inner resistance of the motor shall be neglected.)

$$u_{ind}(t) = 3150 \text{ V}$$

Path

.. Draw the circuit (the circuit breaker can be drawn as a switch), with all voltage and current arrows.

For the maximum voltage on the circuit breaker one has to consider the following:
Result

- external voltage of the voltage source U_{DC}
- voltage $u_{ind}(t)$ induced by the change of the current

The first one is not given in the exercise, and therefore not considered here.

The induced voltage can be calculated by linearizing the following:
$$u_{ind}(t) = -L \frac{di(t)}{dt} \rightarrow u_{ind}(t)$$

$$\&= - L \left\{ \frac{\Delta i}{\Delta t} \right\} \end{align*}$$

With the given details:
$$u_{\text{ind}}(t) = -L \left\{ \frac{0 - I}{t_1 - t_0} \right\} = 50 \cdot 10^{-6} \left\{ \frac{63 \text{ A}}{1 \cdot 10^{-6} \text{ s}} \right\}$$

$$= 3150 \left\{ \frac{\text{Vs}}{\text{A}} \right\} ; \left\{ \frac{\text{A}}{\text{s}} \right\} \end{align*}$$

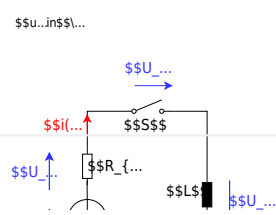

electrical_engineering_and_electronics:task_unkkahm3u0v9azny_with_calculation
 self induction, induction, exam ee2 ss2022

Exercise E10 Series Resonant Circuit
 (written test, approx. 10 % of a 120-minute written test, SS2022)

2. What is the resonance frequency of a series RLC circuit with a resistor of $R = 10 \text{ } \Omega$, an inductor of $L = 10 \text{ mH}$, and a capacitor of $C = 10 \text{ nF}$?
 Result: $f_{\text{res}} = 159.15 \text{ kHz}$

And in this case, what is the value of the resonance frequency f_{res} if the inductor value $L = 0$ would be $X_{\text{C0}} = Z_{\text{RLC}}$?
 Which value would C_0 have for the given f_0 ?

- Path: $C = 10 \text{ nF}$
- $R = 10 \text{ } \Omega$
- $Z_{\text{RLC}} = 250.5 \text{ } \Omega$
- Path: $f_0 = 159.15 \text{ kHz}$
- $R = 10 \text{ } \Omega$

The resonance frequency is given as
$$f_{\text{res}} = \frac{1}{2\pi\sqrt{LC}}$$

$$= \frac{1}{2\pi\sqrt{10 \cdot 10^{-3} \cdot 10 \cdot 10^{-9}}} = 159.15 \text{ kHz}$$

 The total impedance of a series RLC circuit is
$$Z_{\text{RLC}} = X_{\text{C0}} \iff \frac{1}{j\omega C} = Z_{\text{RLC}} \iff C = \frac{1}{\omega Z_{\text{RLC}}}$$

 At resonance the impedance is given purely by the resistor.

With values:
$$C = \frac{1}{2\pi \cdot 100 \cdot 10^6 \cdot 250.5} = 10.6 \text{ nF}$$

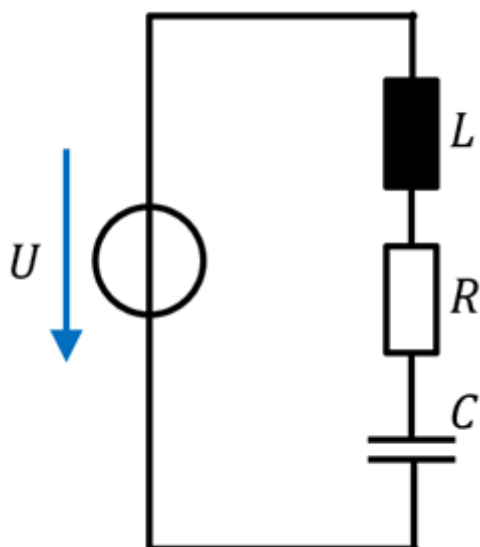

1. What is the impedance \underline{Z}_{RLC} of this real capacitor for $f_0=100 \text{ ~\rm MHz}$? (Phase and magnitude)

Path

The impedance \underline{Z}_{RLC} is given by:
$$\underline{Z}_{RLC} = R + \underline{X}_L + \underline{X}_C \quad \&= R + \{\rm j\}\omega L - \{\{\rm j\}\over{\omega C}\} \quad \&= R + \{\rm j\}\cdot \left(\omega L - \frac{1}{\omega C}\right) \quad \&= R + \{\rm j\}\cdot X_{LC}$$

Putting in the numbers, only for the reactive part X_{LC} :
$$X_{LC} = 2\pi \cdot f_0 \cdot L - \frac{1}{2\pi \cdot f_0 \cdot C} \quad \&= 2\pi \cdot 100 \cdot 10^6 \cdot 60 \cdot 10^{-12} - \frac{1}{2\pi \cdot 100 \cdot 10^6 \cdot 10 \cdot 10^{-9}} \quad \&= -121.45... \text{ ~\rm m}\Omega$$

With the real and imaginary parts, we can derive the magnitude and phase:
$$Z_{RLC} = \sqrt{R^2 + X_{LC}^2} \quad \&= \sqrt{88^2 + (-121.45)^2} \quad \&= 150.0... \text{ ~\rm m}\Omega$$

$$\varphi = \arctan\left(\frac{X_{LC}}{R}\right) = \arctan\left(\frac{-121.45}{88}\right) = -54.07...^\circ$$

[electrical_engineering_and_electronics:task_7el8zljglaazxtw_with_calculation resonant circuit, exam ee2 ss2022](https://mexle.te.hs-heilbronn.de/electrical_engineering_and_electronics:task_7el8zljglaazxtw_with_calculation_resonant_circuit_exam_ee2_ss2022)

From:

<https://mexle.te.hs-heilbronn.de/> - **MEXLE Wiki**

Permanent link:

https://mexle.te.hs-heilbronn.de/electrical_engineering_and_electronics_1/ss2022_exam?rev=1768172850

Last update: **2026/01/12 00:07**

