

Block 11 — Influence and Displacement Field

Student Group

First Name	Surname	Matrikel Nr.

Table of Contents

Block 11 — Influence and Displacement Field	3
11.0 Intro	3
11.0.1 Learning Objectives	3
11.0.2 Preparation at Home	3
11.0.3 90-minute plan	3
11.0.4 Conceptual overview	4
11.1 Core content	4
11.1.1 Electric Field inside of a conductor	4
Note:	5
11.1.2 Electrostatic Induction	5
Note:	7
11.1.3 Electric Field inside of an Isolator	7
11.1.4 Dielectric Constant (Permittivity)	9
11.1.5 Typical Geometries	10
Field of a parallel Plates	10
Field of a coaxial cylindrical Plates	10
11.1.6 Dielectric Strength of Dielectrics	11
11.2 Common pitfalls	12
11.3 Exercises	12
Tasks	12
Task 5.4.1 Simulation	12
Task 5.4.3 electrical Field at different Geometry II (exam task, ca 6 % of a 60 minute exam)	
.....	12
Task 5.4.4 electrical Field at different Geometry II (exam task, ca 6% of a 60 minute exam)	
.....	13
Exercise E1 Electrostatics II (written test, approx. 10 % of a 120-minute written test, SS2024)	
.....	14
Exercise E2 Electrostatics II (written test, approx. 10 % of a 120-minute written test, SS2022)	
.....	14

Task 5.4.5 Simulation	15
Task 5.5.5 Applying Gauss's law: Electric Field of a line charge	16
Embedded resources	17

Block 11 — Influence and Displacement Field

11.0 Intro

11.0.1 Learning Objectives

After this 90-minute block, you can

- explain **electrostatic induction** on conductors and argue why the interior of a conductor is field-free (Faraday cage).
- distinguish the **electric field strength** \vec{E} from the **electric displacement flux density** \vec{D} and state $\vec{D} = \epsilon_0 \vec{E} + \vec{P}$.
- apply **Gauss's law** for the displacement field to simple closed surfaces to relate enclosed charge Q and flux $\oint \vec{D} \cdot d\vec{A}$.
- determine $E(r)$ for parallel-plate and coaxial geometries starting from \vec{D} , then using $\vec{E} = \vec{D} / \epsilon_0$.
- reason about **surface charge density** $\sigma = \Delta Q / \Delta A$ and the normal field at conductor surfaces.
- use typical **relative permittivities** ϵ_r to estimate field reduction in dielectrics.
- interpret **dielectric strength** E_0 (breakdown) and reason about its impact on design limits (safe E , spacing, material choice).

11.0.2 Preparation at Home

Well, again

- read through the present chapter and write down anything you did not understand.
- Also here, there are some clips for more clarification under 'Embedded resources' (check the text above/below, sometimes only part of the clip is interesting).

For checking your understanding please do the following exercises:

- 5.4.1
- 5.4.4
- 5.4.5

11.0.3 90-minute plan

1. Warm-up (10 min):
 1. One-minute recap quiz (Block 10): equipotentials, field lines.
 2. Demo: conductor in external field → Faraday cage effect (refer to the embedded sim in this block).
2. Core concepts & derivations (45 min):
 1. Induction on conductors: charge displacement, $E_{\text{inside}} = 0$, field normal to the surface.

2. Polarization of dielectrics; motivation for introducing \vec{D} .
 3. Definitions: \vec{D} , \vec{E} , ϵ_0 , ϵ_{r} ; Gauss's law with closed surface.
 4. Worked derivations via \vec{D} :
 - Parallel plates: $D=Q/A \rightarrow E = D/(\epsilon_0\epsilon_{\text{r}})$.
 - Coaxial cylinders: $D(r)=Q/(2\pi l r) \rightarrow E(r)=D(r)/(\epsilon_0\epsilon_{\text{r}})$.
 5. Material data: typical ϵ_{r} ; concept of **dielectric strength** E_0 and safe design margins.
3. Practice (25 min):
 1. Short board tasks using pillbox surfaces to find ρ_A on a conductor.
 2. Mixed-dielectric capacitor slice: split voltages via constant D .
 3. Guided use of the embedded sims to observe field/equipotential behavior and verify normal field at surfaces.
 4. Wrap-up (10 min):
 1. Summary box (key formulas, when to start with D vs. E).
 2. Common pitfalls checklist and quick self-test questions.
 3. Preview to Block 12 (capacitors from field viewpoint).

11.0.4 Conceptual overview

1. **Conductors in electrostatics:** free charges move until $E_{\text{inside}}=0$; the surface becomes an equipotential and field lines are perpendicular to it. Induced charges live on the surface (surface density ρ_A).
2. **Dielectrics (polarization):** bound charges shift slightly \rightarrow the macroscopic effect is a reduced E compared to vacuum. This motivates \vec{D} , which "counts causes" (free/enclosed charge) independent of polarization details.
3. **Displacement field & Gauss's law:** for any closed surface, the flux of \vec{D} equals the enclosed charge: $Q=\oint \vec{D}\cdot d\vec{A}$. Choose the surface to exploit symmetry, get \vec{D} first, then \vec{E} via material law.
4. **Permittivity:** $\epsilon=\epsilon_0\epsilon_{\text{r}}$ links \vec{D} and \vec{E} . Larger ϵ_{r} \rightarrow smaller E for the same D (same free charge).
5. **Design limit:** when $|E|$ exceeds the **dielectric strength** E_0 , breakdown occurs \rightarrow current flows. Safe design keeps $|E|\ll E_0$ by material choice and geometry (spacing, shaping to avoid high curvature).

11.1 Core content

11.1.1 Electric Field inside of a conductor

As seen in [Block10](#), any hole inside a conductor does neither show field lines nor an electric field. This

is called **Faraday cage** or Faraday shield.

Wo we want to have a look onto an uncharged object in an external field. Also here any hole inside does not show an electric field

The reason for that is, that the outer field gets cancelled out by an opposing inner electric field.

A charge displacement on the external surface (induced by the external field) is the reason for that opposing inner field.

Please have a look onto the yellow and blue color in **figure 1** to see this charge displacement

Fig. 1: field of a pointy object in an external field (field line density is not correct)

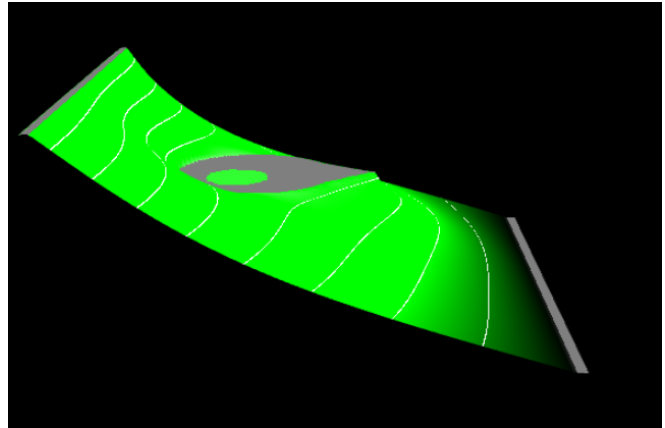

Note:

Any external electric field causes a charge displacement on an conductor in such a way, that there is no internal field inside the material (neither in holes nor in the material itself)

11.1.2 Electrostatic Induction

In a thought experiment, an uncharged conductor (e.g., a metal plate) is brought into an electrostatic field (**figure 2**). The external field or the resulting Coulomb force causes the moving charge carriers to be displaced.

Fig. 2: Viewing the induced charge separation

Fig. 3: field lines by charge separation

Results:

- The charge carriers are still distributed on the surface.
- Now, equilibrium is reached when just so many charges have moved, that the electric field inside the conductor disappears (again).
- The field lines leave the surface again at right angles. Again, a parallel component would cause a charge shift in the metal.

This effect of charge displacement in conductive objects by an electrostatic field is referred to as **electrostatic induction** (in German: *Influenz*). Induced charges can be separated (figure 2 right). If we look at the separated induced charges without the external field, their field is again just as strong in magnitude as the external field only in the opposite direction.

Note:

1. The location of an induced charge is always on the conductor surface. This results in a surface charge density $\varrho_A = \frac{\Delta Q}{\Delta A}$
2. The conductor surface in the electrostatic field is always an equipotential surface. Thus, the field lines always originate and terminate perpendicularly on conductor surfaces.
3. The interior of the conductor is always field-free (Faraday effect: metallic enclosures shield electric fields).

How can the conductor surface be an equipotential surface despite different charges on both sides? Equipotential surfaces are defined only by the fact that the movement of a charge along such a surface does not require/produce a change in energy. Since the interior of the conductor is field-free, movement there can occur without a change in energy. As the potential between two points is independent of the path between them, a path along the surface is also possible without energy expenditure.

11.1.3 Electric Field inside of an Isolator

But how is it like for an isolator in an external field?

There are no free charges in an isolator - so, is there no compensation of the external field inside the isolator at all?

The simulation in figure 4 shows something different: it looks like, that there is some compensation but not a complete one.

Fig. 4: field of a pointy object in an external field (field line density is not correct)

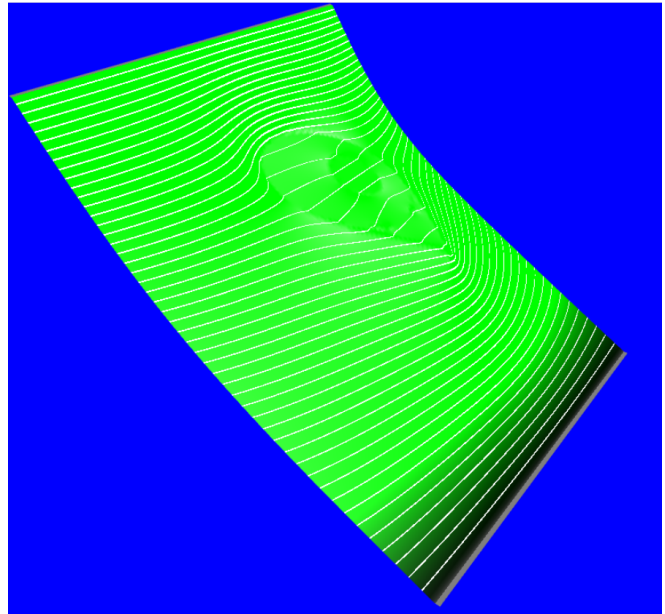

So, let us look into an isolator: The [figure 5](#) shows a scetch of the inner of an isolator in an electric field.

Most of the isolators have a bipolar property (e.g. [water](#)): Its material consists of units, which are partially positively charged and partially negatively charged. This units cannot move, but they might get bend and rotated. This induces some charges on the surface, and these compensate some of the electric field by an opposing field.

Fig. 5: field of a pointy object in an external field (field line density is not correct)

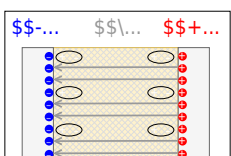

So the root-cause-path is:

1. We have initially the external electric field.
2. This induces the counteracting field by bending the dipoles.
3. The internal measurable electric field is compensated

To have an uncompensated field in the following the **electric displacement flux density** \vec{D} is introduced. The electric displacement flux density is only focusing on the cause of the electric fields. As we have seen, its effect can differ since the space can also “hinder” the electric field in an effect.

The electric displacement flux density is only related to the causing charges Q . This relationship is shown in the following.

$$\boxed{Q = \int_{\text{d}} Q = \oint_{\text{A}} \vec{D} \cdot \text{d}\vec{A}}$$

The symbol \oint_{A} denotes that there is a closed surface used for the integration.

The meaning of the formula is: The “sum” of the D -field emanating over the surface is thus just as large as the sum of the charges contained therein, since the charges are just the sources of this field.

This can be compared with a bordered swamp area with water sources and sinks:

- The sources in the marsh correspond to the positive charges, and the sinks to the negative charges. The formed water corresponds to the D -field.
- The sum of all sources and sinks equals, in this case, just the water stepping over the edge.

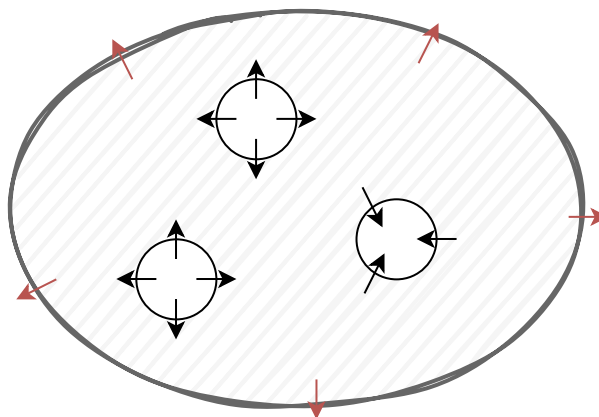

Fig. 6: Comparison to swamp

11.1.4 Dielectric Constant (Permittivity)

Dielectric materials reduce the electric field inside them. How much die field is reduced is given by a material dependent constant the **dielectric constant** or **permittivity** ϵ_r . It is unitless and a ratio related to the unhindered field in vacuum.

$$\frac{D}{E} = \epsilon = \epsilon_0 \cdot \epsilon_r \quad \boxed{D = \epsilon_0 \cdot \epsilon_r \cdot E}$$

Some values of the relative permittivity ϵ_r for dielectrics are given in [table 1](#).

material	relative permittivity ϵ_r for low frequencies
air	1.0006
paper	2
PE, PP	2.3
PS	2.5
hard paper	5
glass	6...8
water (20°C)	80

Tab. 1: relative permittivity

11.1.5 Typical Geometries

The “new” D -field is a nice tool, which helps to derive the E -field more easily.

This shall be shown with the two most common geometries (which are the only one necessary for this course).

Field of a parallel Plates

- Nearly all of the field is between the plate (see figure 7 top), when the distance between the plates is much smaller than the width of the plates.
→ Idealization: all of the field is inside. There is neither a stray field on the side, nor a field on top / below the structure.
- All of the D -field of the charges is between the plates, and therefore through the area A of the plates (see figure 7 bottom).
→ The D -Field is given as: $D = \frac{Q}{A}$
- Given $D = \epsilon_0 \cdot \epsilon_r \cdot E$, the electric field E is: $E = \frac{Q}{\epsilon_0 \cdot \epsilon_r \cdot A}$

Fig. 7: field of parallel plates (field line breaks are not correct)

Field of a coaxial cylindrical Plates

- All of the field is between the plate (see figure 8 top).
- All of the D -field of the charges on the inner plate penetrates through any cylindrical area $A(l,r) = 2 \pi \cdot l \cdot r$.
→ The D -Field is given as: $D = \frac{Q}{2 \pi \cdot l \cdot r}$
- Again given $D = \epsilon_0 \cdot \epsilon_r \cdot E$, the electric field E is: $E = \frac{Q}{\epsilon_0 \cdot \epsilon_r \cdot 2 \pi \cdot l \cdot r}$

Fig. 8: field of coaxial cylindrical plates

11.1.6 Dielectric Strength of Dielectrics

- The dielectrics act as insulators. The flow of current is therefore prevented
- The ability to insulate is dependent on the material.
- If a maximum electric field E_0 is exceeded, the insulating ability is eliminated.
 - One says: The insulator breaks down. This means that above this electric field, a current can flow through the insulator.
 - Examples are: Lightning in a thunderstorm, ignition spark, glow lamp in a [phase tester](#)
 - The maximum electric field E_0 is referred to as **dielectric strength** (in German: *Durchschlagfestigkeit* or *Durchbruchfeldstärke*).
 - E_0 depends on the material (see [table 2](#)), but also on other factors (temperature, humidity, ...).

Material	Dielectric strength E_0 in $\{\ \rm kV/mm\}$
air	$\rm 0.1...0.3$
SF6 gas	$\rm 8$
insulating oils	$\rm 5...30$
vacuum	$\rm 20...30$
quartz	$\rm 30...40$
PP, PE	$\rm 50$
PS	$\rm 100$
distilled water	$\rm 70$

Tab. 2: Dielectric strength

11.2 Common pitfalls

- Mixing up **cause** and **effect**: using $\oint \vec{E} \cdot d\vec{A}$ to count charge. Use \vec{D} for Gauss's law with charge; convert to \vec{E} only via $\vec{E} = \vec{D} / (\epsilon_0 \epsilon_r)$.
- Forgetting that the **interior of a conductor is field-free** in electrostatics and that E is **normal** to an ideal conducting surface (no tangential E on the surface).
- Assuming induced charges fill the **volume** of a conductor. They reside on the **surface**; use σ , not a volume density.
- Ignoring that **D is continuous** in the normal direction across simple dielectric interfaces when no free surface charge is present; consequently, the **electric field changes** with ϵ_r .
- Treating ϵ_r as a constant in all contexts. Real materials can be frequency/temperature dependent; here we use low-frequency values as stated.
- Checking breakdown with voltage only. The limit is on **field** E ; always relate geometry (e.g., plate spacing, curvature) to E and compare to **E_0** with units (e.g., kV/mm).

11.3 Exercises

Tasks

Task 5.4.1 Simulation

Fig. 9: examples for equipotential lines

In the simulation in [figure 9](#), the equipotential lines and electric field at different objects can be represented. In the beginning, the situation of an infinitely long cylinder in a homogeneous electric field is shown. The solid lines show the equipotential surfaces. The small arrows show the electric field.

1. What is the angle between the field on the surface of the cylinder?
2. Once the option `Flat View` is deactivated, an alternative view of this situation can be seen. Additionally, charged test particles can be added with `Display: Particles (Vel.)`. This alternative view looks similar to what other physical fields?
3. What can be said about the potential distribution on the cylinder?
4. On the left half of the field lines enter the body, on the right half, they leave the body. What can be said about the charge carrier distribution at the surface? Check also the representation `floor: charge!`
5. Is there an electric field inside the body?
6. Is this cylinder metallic, semiconducting, or insulating?

Task 5.4.3 electrical Field at different Geometry II (exam task, ca 6 % of a 60 minute exam)



The figure on the right shows an arrangement of ideal metallic conductors (gray) with specified charge. In white a dielectric (e.g. vacuum) is shown. Several designated areas are shown by green dashed frames, which are partly inside the objects.

Arrange the designated areas clearly according to ascending field strength (magnitude)! Indicate also, if designated areas have quantitatively the same field strength.

Result

$$a = c < d < b$$

Task 5.4.4 electrical Field at different Geometry II (exam task, ca 6% of a 60 minute exam)



The figure on the right shows an arrangement of ideal metallic conductors (gray) with specified charge. In white a dielectric (e.g. vacuum) is shown. Several designated areas are shown by green dashed frames, which are partly inside the objects.

Arrange the designated areas clearly according to ascending field strength (magnitude)! Indicate also, if designated areas have quantitatively the same field strength.

Result

$$a = c < b < d$$

Exercise E1 Electrostatics II

(written test, approx. 10 % of a 120-minute written test, SS2024)

You must analyze an aluminum profile for usage in an environment critical for electrostatic discharge.

The figure on the right shows the cross-section of the aluminum element (hatched). During the application, it might get charged up. All areas in white consist of air (= dielectric).

Six designated areas are shown by dashed frames and numbers n, which are partly inside the object.

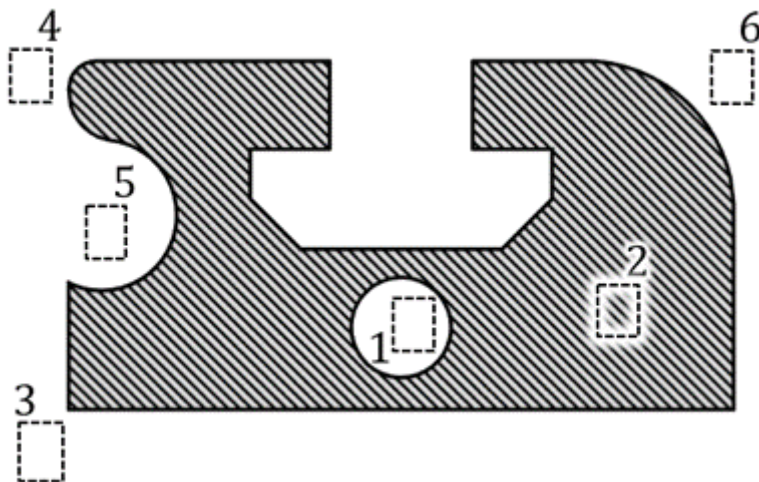
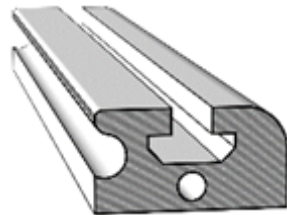

Arrange the designated areas clearly according to ascending field strengths $|\vec{E}_n|$ (absolute magnitude)! Indicate also, if designated areas have quantitatively the same field strength.

Result

$$|E_1|=|E_2|=0 < |E_5| < |E_6| < |E_4| < |E_3|$$

Exercise E2 Electrostatics II

(written test, approx. 10 % of a 120-minute written test, SS2022)

The figure below shows an arrangement of ideal metallic conductors (gray hatched) charged up to $q = +1 \text{ nC}$.

In white a dielectric (e.g. vacuum) is shown.

Several designated areas are shown by dashed frames and numbers x , which are partly inside the object.

Arrange the designated areas clearly according to ascending field strengths $|\vec{E}_x|$ (absolute magnitude)!

Indicate also, if designated areas have quantitatively the same field strength.

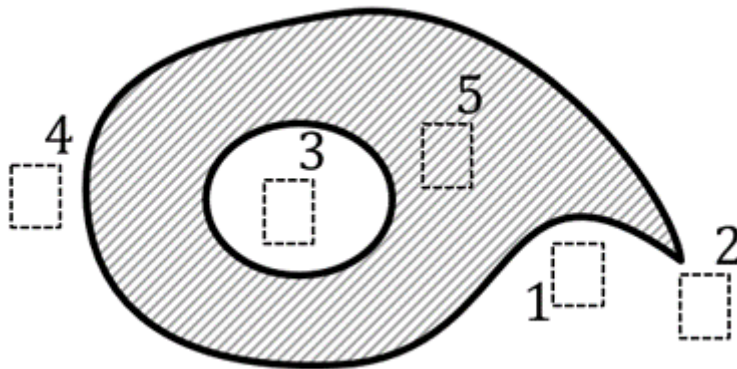

Result

$$|E_3| = |E_5| = 0 < |E_1| < |E_4| < |E_2|$$

Task 5.4.5 Simulation

Given is the two-dimensional component shown in [figure 10](#). The component shall be charged positively.

In the picture, there are 4 positions marked with numbers.

Order the numbered positions by increasing charge density!

Fig. 10: examples for conductive charged 2-dimensional component

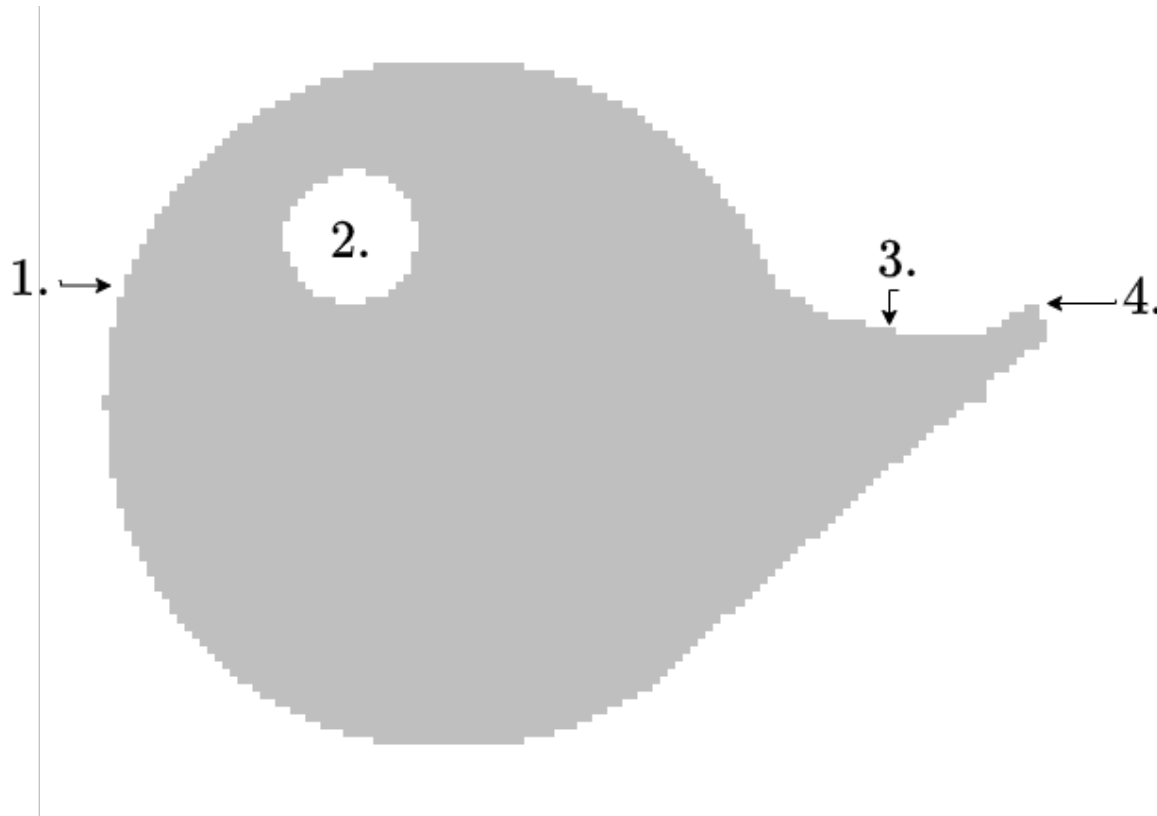

Result

$$\varrho_2 < \varrho_3 < \varrho_1 < \varrho_4$$

Fig. 11: examples of field lines

Task 5.5.5 Applying Gauss's law: Electric Field of a line charge

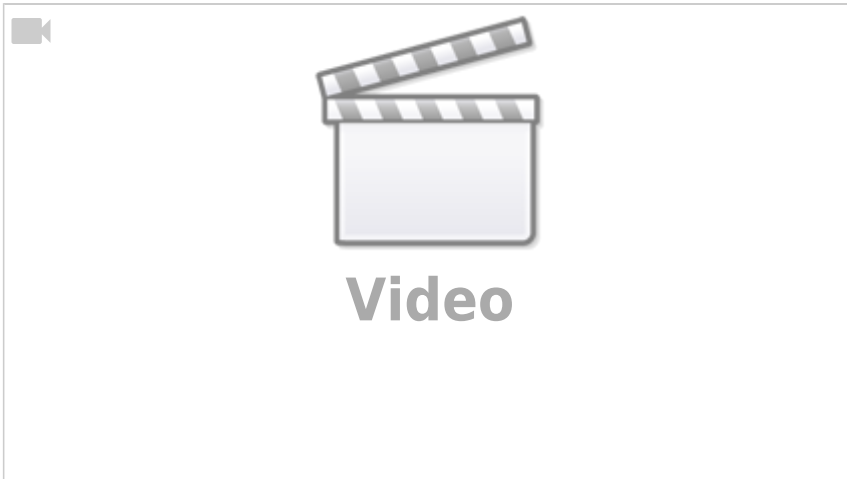

Embedded resources

Application of electrostatic induction: Protective Parallel-plate capacitor and dielectric breakdown bag against electrostatic charge/discharge

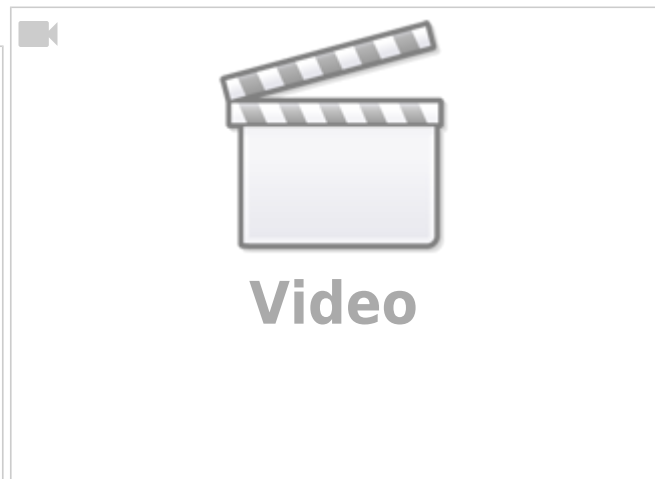
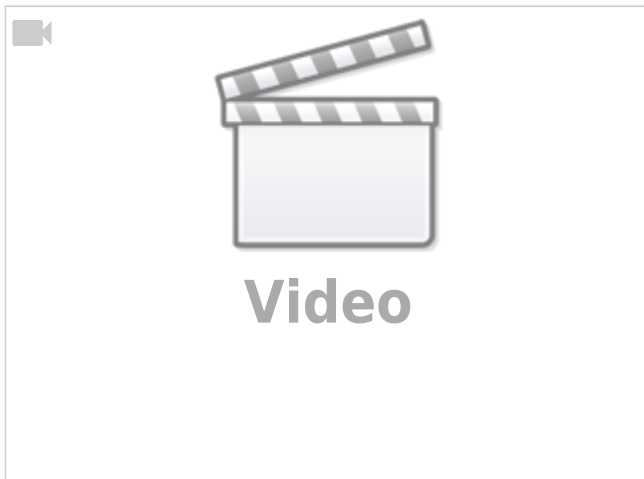

From:
<https://mexle.te.hs-heilbronn.de/> - **MEXLE Wiki**

Permanent link:
https://mexle.te.hs-heilbronn.de/electrical_engineering_and_electronics_1/block11

Last update: **2026/01/10 13:41**

