

Block 08 — Two-terminal theory and transforms

Student Group

First Name	Surname	Matrikel Nr.

Table of Contents

- Block 08 — Two-terminal theory and transforms** 3
- 9.0 Intro** 4
 - 9.0.1 Learning Objectives 4
 - 9.0.2 Preparation at Home 4
 - 9.0.3 90-minute plan 4
 - 9.0.4 Conceptual Overview 5
- 9.1 Core content** 5
 - 9.1.1 Two-Terminal Theory / One-Port Theory 5
 - Hint: 7
 - 9.1.2 Superposition Principle 7
 - Example 1 - from an interview of a consulting company 7
 - Example 2 - Spring Force and Displacement 7
 - Notice: 8
 - Example 9
- 9.2 Common Pitfalls** 10
- 9.3 Exercises** 10
 - Longer Exercises 10
 - Exercise E4.5.1 Converting a bipolar signal to a unipolar signal (HARD, not from written test) 11
 - Circuit 1 : only consider U_{S} , ignore U_{I} 11
 - Circuit 2 : only consider U_{I} , ignore U_{S} 12
 - Superposition: Let's sum it up! 13
 - Situation I : $U_{\text{I,min}} = -15 \text{ V}$ shall create $U_{\text{O,min}} = 0 \text{ V}$ 14
 - Situation II : $U_{\text{I,max}} = +15 \text{ V}$ shall create $U_{\text{O,max}} = 3.3 \text{ V}$ 14
 - Aufgabe 4.5.2: open circuit voltage via superposition (exam task, approx. 12 % of a 60-minute exam, WS2020) 15

Exercise 4.5.3 -Variation: open circuit voltage via superposition (exam task, approx. 12 % of a 60-minute exam, WS2020)	18
Exercise 4.5.4 - Variation: open circuit voltage via superposition (exam task, approx. 12 % of a 60-minute exam, WS2020)	20
Embedded resources	20

Block 08 — Two-terminal theory and transforms

Fig. 1: examples for networks

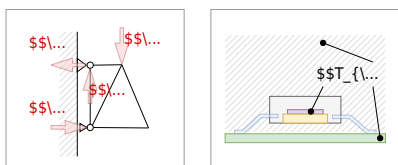

Network analysis plays a central role in electrical engineering. It is so important because it can be used to simplify what at first sight appear to be complicated circuits and systems to such an extent that they can be understood and results derived from them.

In addition, networks also occur in other areas, for example, the momentum flux through a truss or the heat flux through individual hardware elements ([figure 1](#), or [an example for heat flow through electronics](#)). The concepts shown below can also be applied to these networks.

On the [wiki page for network analysis](#) the different methods are described very well in a compact way

9.0 Intro

9.0.1 Learning Objectives

- Define **terminal** and **port**; distinguish **one-port** (two-terminal) vs. **two-port** views; identify input/output variables (U, I) at a port.
- Apply **source transformations** between a voltage source with series R and a current source with parallel R using $U_0 = I_0 R$; state validity conditions (linear, bilateral, time-invariant networks).
- Construct **Thevenin** and **Norton** equivalents seen at a port: find U_{oc} , I_{sc} , and $R_{\text{Th}} = R_{\text{N}}$ by deactivating sources; relate $U_{\text{Th}} = U_{\text{oc}}$, $R_{\text{Th}} = R_{\text{N}}$, $I_{\text{No}} = I_{\text{sc}}$.
- Use the **superposition principle** to compute branch currents/voltages in multi-source linear networks; outline the deactivate–solve–sum workflow.
- Combine transforms to reduce complex resistive networks to an **unloaded / loaded divider** and to size R_{L} for given performance goals (tie-in to Block 07 figures).

9.0.2 Preparation at Home

And again:

- Please read through the following chapter.
- Also here, there are some clips for more clarification under 'Embedded resources'.

For checking your understanding please do the following exercise:

- 4.5.3

9.0.3 90-minute plan

1. Warm-up (8 min):
 1. Quick quiz on passive/active sign convention and $P = U \cdot I$ (from Block 07).
 2. Identify ports and choose measurement directions on 2–3 small circuits.
2. Core concepts & derivations (58 min):
 1. (1) **Source transformations** ($U_0 \rightarrow I_0$, shared R), permissible assumptions, and fast checks (10 min).
 2. (2) **Thevenin/Norton construction** at a chosen port: U_{oc} , I_{sc} , $R_{\text{Th}} = R_{\text{N}}$ (18 min).
 3. (3) **Superposition method**: deactivate sources, compute partial results, sum; worked DC example (15 min).
3. Practice (20 min):
 1. Pair exercise set: reduce a 3-source network to Thevenin, then find U_{L} , I_{L} .
4. Wrap-up (5 min):
 1. Summary table (when to use which method); minute paper: “One thing I can now do, one

question I still have.”

9.0.4 Conceptual Overview

1. **Port thinking:** Draw a virtual cut around the “rest of the world”. At that boundary (two terminals), everything inside looks like an equivalent **linear source** (Thevenin/Norton) to everything outside.
2. **Source transformations:** A series source (U_0, R) is equivalent to a parallel source (I_0, R) if $U_0 = I_0 R$. Use them to simplify ladders and to expose a clean port.
3. **Thevenin/Norton from measurements:**
 1. Open-circuit the load \rightarrow measure/compute $U_{\text{oc}} = U_{\text{Th}}$.
 2. Short the load (only if safe/valid) $\rightarrow I_{\text{sc}} = I_{\text{No}}$.
 3. Deactivate sources \rightarrow compute the internal resistance $R_{\text{i}} = R_{\text{Th}} = R_{\text{No}}$.
4. **Superposition (linear networks only):** Voltages and currents **add**; powers do **not**. For each source: deactivate the others (ideal U -sources \rightarrow short; ideal I -sources \rightarrow open), solve the partial, then sum with signs.
5. **Choosing a method:** Use source transforms for quick topology changes, Thevenin/Norton to isolate a load, and superposition when multiple sources block easy reduction.

9.1 Core content

9.1.1 Two-Terminal Theory / One-Port Theory

Fig. 1: examples for networks

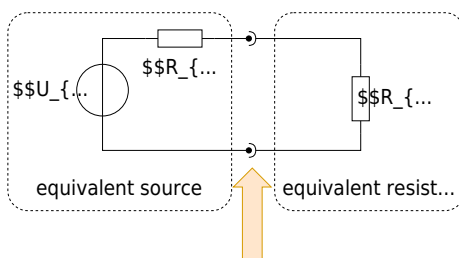

In order to understand the two-terminal theory / one-port theory, we first have to understand what a Terminal and port is.

So, have a look to [figure 1](#):

1. A terminal or pole is simply an (imaginary or real) connector. This is shown in the diagram by a filled circle on one wire, plus a semicircle on the other wire
2. A port is given by two terminals

But, how could this help us in simplifying circuits?

Well: Usually, the voltage over or the current into one component or a group of component has to be found.

Now, it is practical, that

- you can substitute every passive linear part (= consisting only of resistors) by a single equivalent resistor.
- you can substitute every active linear part (= consisting of resistors and sources) by a single equivalent linear source.

A linear part is here a circuit consisting of linear components. In general, ohmic resistors, sources, capacitors and inductors are linear - here, we only look onto resistors. (non-linear are most of the semiconductor components, like diodes).

So, what can we do? Once you search for a distinct voltage or current:

1. Imagine a virtual cut around this part. You get a passive linear part and a active linear part.
2. Calculate the single equivalent resistor and single equivalent linear source. You get an unloaded voltage divider.
3. Calculate the voltage divider

Voilà, we have a way to find our desired voltage or current in a complicated circuitry.

Hint:

There is a trick to get the internal resistance of the source easily, so without continuous back-and-forth between linear voltage source and linear current source:

When one is only interested in the resistance of a complex circuit, do as follows:

1. substitute every ideal source with its internal resistance (ideal voltage source → short circuit, ideal current source → unconnected).
2. calculate the equivalent resistance by means of series and parallel sub-circuits.

9.1.2 Superposition Principle

The superposition principle shall first be illustrated by some examples:

Example 1 - from an interview of a consulting company

Task: Three students are to fill a pool. If Alice has to fill it alone, she would need 2 days. Bob would need 3 days and Carol would need 4 days. How long would it take all three to fill a pool if they helped together?

The question sounds far off-topic at first but is directly related. The point is that to solve it, filling the pool is assumed to be linear. So Alice will fill $\frac{1}{2}$, Bob $\frac{1}{3}$, and Carol $\frac{1}{4}$ of the pool per day. So on the first day, $\frac{1}{2} + \frac{1}{3} + \frac{1}{4} = \frac{6 + 4 + 3}{12} = \frac{13}{12}$ of the pool filled. So the three of them need $\frac{12}{13}$ of a day.

However, this solution path is only possible because in linear systems the partial results can be added.

Example 2 - Spring Force and Displacement

Fig. 3: mechanical spring

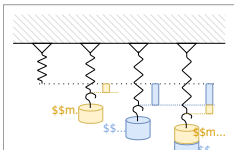

Task: A mechanical, linear spring is displaced due to masses m_1 and m_2 in the Earth's gravitational field (see [figure 3](#)). What is the magnitude of the deflection if both masses are attached simultaneously?

Again, a linear law is used here:
$$\vec{s} = f(\vec{F}) = -D \cdot \vec{F}$$

The (seemingly trivial) approach applies here:
$$\vec{s}_{1+2} = f(\vec{F}_1 + \vec{F}_2) = -D \cdot (\vec{F}_1 + \vec{F}_2) = -D \cdot \vec{F}_1 - D \cdot \vec{F}_2 = f(\vec{F}_1) + f(\vec{F}_2) = \vec{s}_1 + \vec{s}_2$$

Notice:

In a physical system in which effect and cause are linearly related, the effect of each cause can first be determined separately. The total effect is then the sum of the individual effects.

For electrical engineering this principle was described by [Hermann von Helmholtz](#):

The currents in the branches of a linear network are equal to the sum of the partial currents in the branches concerned caused by the individual sources.

Thus, in the superposition method, the current (or voltage) sought in a circuit with multiple sources can be viewed as a superposition of the resulting currents (or voltages) of the individual sources. Simple view of the superposition principle

The “recipe” for the overlay is as follows:

1. Choose the next source x
2. Replace all ideal sources with their respective equivalent resistors:

1. ideal voltage sources by short circuits
2. ideal current sources by an open line
3. Calculate the partial currents sought in the branches considered.
4. Go to the next source $x=x+1$ ¹⁾, and to point 2, as long as the partial currents of all sources have not been calculated.
5. Add up the partial currents in the branches under consideration, observing the correct sign.

This procedure is explained again in more detail using examples in the two videos on the right.

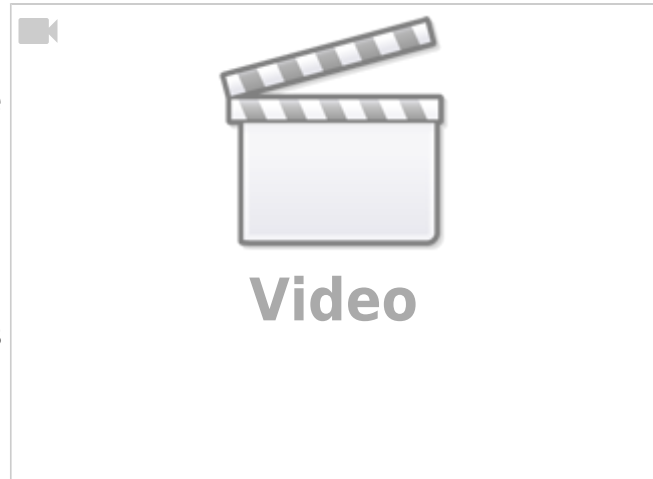

A more complex example of the superposition method

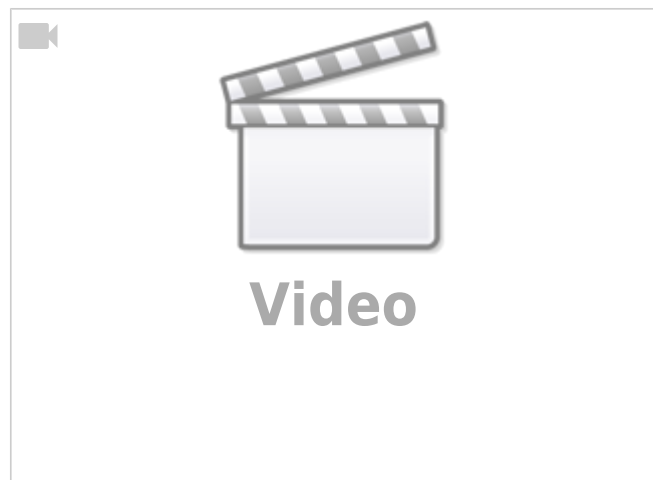

Example

Fig. 4: example circuit with superposition

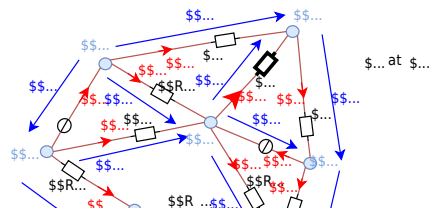

9.2 Common Pitfalls

- **Deactivating sources incorrectly:** replacing an ideal voltage source with an **open** (instead of a short), or an ideal current source with a **short** (instead of an open).
- **Superposing powers:** only **u** and **i** superpose; **P** does not. Compute powers **after** summing.
- **Illegal short/open tests:** shorting across an element that cannot be shorted (e.g., an ideal current source without care) or opening where it breaks circuit definitions.
- **Sign/arrow mismatches:** mixing passive/active sign conventions leads to wrong partial signs in superposition.
- **Applying linear methods to non-linear/time-varying parts:** Thevenin/Norton and superposition require **linearity** (and usually bilateral behavior).
- **Ignoring loading:** using the unloaded divider ratio $\frac{R_2}{R_1+R_2}$ while a finite R_L is attached \rightarrow systematic voltage error.

9.3 Exercises

Longer Exercises

Exercise E4.5.1 Converting a bipolar signal to a unipolar signal (HARD, not from written test)

What is the minimum and maximum current that can be drawn from the sensor? The sensor is a bipolar signal source with a range of $[-15 \dots 15 \text{ V}]$, and the microcontroller input can read values in the range $[0 \dots 3.3 \text{ V}]$. The sensor can supply a maximum current of $I_{\text{max}} = 1 \text{ mA}$. For the internal resistance of the microcontroller, input applies:

Solution
 The sensor resistance is $R_S = 15 \text{ k}\Omega$

For conditioning, the input signal is to be fed via the series resistor R_3 to the center potential of a voltage divider R_1, R_2 with R_1 to a supply voltage U_S .
 We can choose R_3 arbitrarily. Here I choose a nice value to get integer values for the other resistors. $R_1 = 25 \text{ k}\Omega, R_2 = 25 \text{ k}\Omega, R_3 = 10 \text{ k}\Omega$.
 The following circuit diagram shows the situation. Be aware that the resistor values are not correct!

Based on the circuit, the following values from the supply voltage U_S to the center of the divider R_1, R_2 are $U_O = U_S \cdot \frac{R_2}{R_1 + R_2} = U_S \cdot \frac{25}{50} = \frac{U_S}{2}$.
 The current I flowing through the divider is $I = \frac{U_S}{R_1 + R_2} = \frac{U_S}{50 \text{ k}\Omega}$.
 The voltage across R_3 is $U_{R3} = I \cdot R_3 = \frac{U_S}{50 \text{ k}\Omega} \cdot 10 \text{ k}\Omega = \frac{U_S}{5}$.

Find the relationship between $R_1, R_2,$ and R_3 using superposition.

This led to the formula based on the Kirchhoff's nodal rule:

$$\frac{U_O}{R_1} + \frac{U_O}{R_2} + \frac{U_O}{R_4} = \frac{U_S}{R_1} + \frac{U_I}{R_4} - \frac{U_O}{R_2}$$

 Determine suitable values for $R_1, R_2,$ and R_3 .
 What values for $R_1, R_2,$ and R_3 from the BROKEN LINK: [E4.4 series LINK BROKEN](#) can be used to do this?

Solution
 The formula can be rearranged, with all terms containing U_O on the left side:

$$\frac{U_O}{R_1} + \frac{U_O}{R_2} + \frac{U_O}{R_4} = \frac{U_S}{R_1} + \frac{U_I}{R_4} - \frac{U_O}{R_2}$$

$$U_O \cdot \left(\frac{1}{R_1} + \frac{1}{R_2} + \frac{1}{R_4} \right) = \frac{U_S}{R_1} + \frac{U_I}{R_4}$$

 Using superposition, we create two separate circuits where one source is considered.

For these two circuits we calculate $U_{A(1)}$ and $U_{A(2)}$.
 Both sides can be multiplied by $(R_1 R_2 R_4)$ in order to get rid of the fractions:

$$U_O \cdot (R_2 R_4 + R_1 R_4 + R_1 R_2) = R_2 R_4 U_S + R_1 R_2 U_I$$

$$U_O = \frac{R_2 R_4 U_S + R_1 R_2 U_I}{R_2 R_4 + R_1 R_4 + R_1 R_2}$$

Circuit 1: only consider U_S , ignore U_I

$$U_O = \frac{R_2 R_4 U_S}{R_2 R_4 + R_1 R_4 + R_1 R_2}$$

The last formula was just the result we also got by the superposition but by more thinking.
 So, sometimes there is an easier way...

- Unluckily, there is no simple way to know before, what way is the easiest.
- Luckily, all ways lead to the correct result.

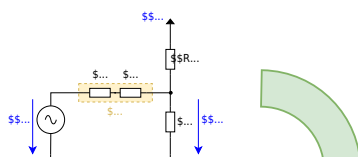

$$\begin{aligned}
 U_{\text{O}}^{(1)} &= U_{\text{S}} \cdot \frac{R_2 \parallel R_4}{R_1 + R_2 \parallel R_4} = U_{\text{S}} \cdot \frac{\frac{R_2 R_4}{R_2 + R_4}}{R_1 + \frac{R_2 R_4}{R_2 + R_4}} \\
 &= U_{\text{S}} \cdot \frac{R_2 R_4}{R_1 R_2 + R_1 R_4 + R_2 R_4}
 \end{aligned}$$

Circuit 2 : only consider U_{I} , ignore U_{S}

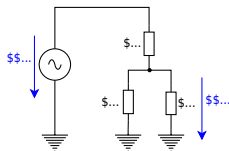

$$\begin{aligned} U_{\text{O}}^{(2)} &= U_{\text{I}} \cdot \frac{R_1 || R_2}{R_4 + R_1 || R_2} = U_{\text{I}} \cdot \frac{\frac{R_1 R_2}{R_1 + R_2}}{R_4 + \frac{R_1 R_2}{R_1 + R_2}} \\ &= U_{\text{I}} \cdot \frac{R_1 R_2}{R_4 R_1 + R_4 R_2 + R_1 R_2} \end{aligned}$$

Superposition: Let's sum it up!

These two intermediate voltages for the single sources have to be summed up as $U_{\text{O}} = U_{\text{O}}^{(1)} + U_{\text{O}}^{(2)}$.

When deeper investigated, one can see that the denominator for both $U_{\text{O}}^{(1)}$ and $U_{\text{O}}^{(2)}$ is the same.

We can also simplify further when looking at often-used sub-terms (here: R_2)

$$\begin{aligned} U_{\text{O}} &= \frac{1}{R_4 R_1 + R_4 R_2 + R_1 R_2} \\ &\cdot (U_{\text{S}} \cdot R_2 R_4 + U_{\text{I}} \cdot R_1 R_2) \parallel U_{\text{O}} \cdot (R_4 R_1 + R_4 R_2 + R_1 R_2) \\ &= U_{\text{S}} \cdot R_2 R_4 + U_{\text{I}} \cdot R_1 R_2 \parallel U_{\text{O}} \cdot (\frac{R_1 R_4}{R_2} + R_4 + R_1) \\ &= U_{\text{S}} \cdot R_4 + U_{\text{I}} \cdot R_1 \tag{1} \end{aligned}$$

The formula (1) is the general formula to calculate the output voltage U_{O} for a changing input voltage U_{I} , where the supply voltage U_{S} is constant.

Now, we can use the requested boundaries:

1. For the minimum input voltage $U_{\text{I}} = -15 \text{ V}$, the output voltage shall be $U_{\text{O}} = 0 \text{ V}$
2. For the maximum input voltage $U_{\text{I}} = +15 \text{ V}$, the output voltage shall be $U_{\text{O}} = 3.3 \text{ V}$

This leads to two situations:

Situation I : $U_{\text{I,min}} = -15 \text{ V}$ shall create $U_{\text{O,min}} = 0 \text{ V}$

We put $U_{\text{A}} = 0 \text{ V}$ in the formula (1) :
$$0 = U_{\text{S}} \cdot R_4 + U_{\text{I,min}} \cdot R_1 - U_{\text{I,min}} \cdot R_1 + U_{\text{S}} \cdot R_4 \cdot \frac{R_1}{R_4} = -\frac{U_{\text{S}}}{U_{\text{I,min}}} = k_{14} \tag{2}$$

So, with formula (2), we already have a relation between R_1 and R_4 .
Yeah \square

The next step is situation 2

Situation II : $U_{\text{I,max}} = +15 \text{ V}$ shall create $U_{\text{O,max}} = 3.3 \text{ V}$

We use formula (2) to substitute $R_1 = k_{14} \cdot R_4$ in formula (1), and:
$$U_{\text{O,max}} \cdot (k_{14} \cdot \frac{R_4^2}{R_2} + R_4 + k_{14} \cdot R_4) = U_{\text{S}} \cdot R_4 + U_{\text{I,max}} \cdot k_{14} \cdot R_4 \cdot \frac{R_4}{R_2} + U_{\text{O,max}} \cdot (k_{14} \cdot \frac{R_4}{R_2} + 1 + k_{14}) = U_{\text{S}} + U_{\text{I,max}} \cdot k_{14} \cdot \frac{R_4}{R_2} + 1 + k_{14} = \frac{U_{\text{S}} + U_{\text{I,max}} \cdot k_{14}}{U_{\text{O,max}}} \cdot \frac{R_4}{R_2} = \frac{U_{\text{S}} + U_{\text{I,max}} \cdot k_{14}}{U_{\text{O,max}}} \cdot \frac{R_4}{R_2} - (1 + k_{14}) \cdot \frac{R_4}{R_2} = \frac{U_{\text{S}} + U_{\text{I,max}} \cdot k_{14}}{k_{14} \cdot U_{\text{O,max}}} - \frac{1 + k_{14}}{k_{14}} \tag{3}$$

So, another relation for R_4 and R_2 . \square

So, to get values for the relations, we have to put in the values for the input and output voltage conditions. For k_{14} we get by formula (2):
$$k_{14} = \frac{R_1}{R_4} = -\frac{5 \text{ V}}{-15 \text{ V}} = \frac{1}{3} \end{align*}$$

This value k_{14} we can use for formula (3):
$$\frac{R_4}{R_2}$$

$$\frac{1}{R_2} = \frac{5 \text{ V} + 15 \text{ V} \cdot \left\{ \frac{1}{3} \right\}}{3.3 \text{ V} \cdot \left\{ \frac{1}{3} \right\}} - \left\{ \frac{1 + \left\{ \frac{1}{3} \right\}}{\left\{ \frac{1}{3} \right\}} \right\} \approx 5.09$$

We could now - theoretically - arbitrarily choose one of the resistors, e.g., R_2 , and then calculate the other two.

But we must consider another boundary, a boundary for R_S . The maximum voltage and the maximum current are given for the sensor. By this, we can calculate R_S :

$$R_S = \frac{U_{\text{OC}}}{I_{\text{SC}}} = \frac{U_{\text{S,max}}}{I_{\text{S,max}}} = \frac{15 \text{ V}}{1 \text{ mA}} = 15 \text{ k}\Omega$$

Therefore, $R_4 = R_S + R_3$ must be larger than this.

Aufgabe 4.5.2: open circuit voltage via superposition (exam task, approx. 12 % of a 60-minute exam, WS2020)

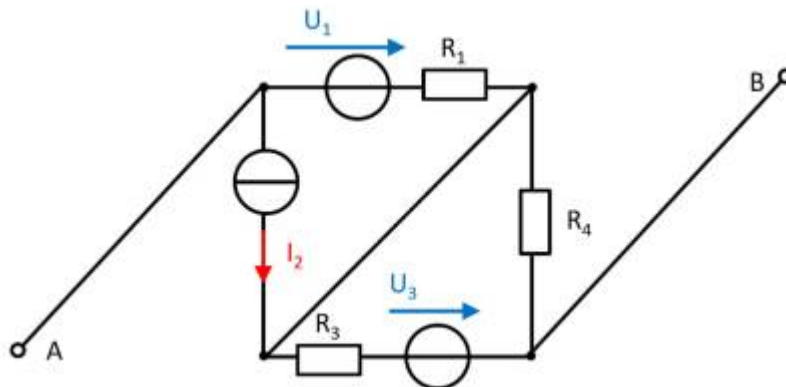

A circuit is given with the following parameters

$$R_1 = 5 \text{ }\Omega$$

$$U_1 = 2 \text{ V}$$

$$I_2 = 1 \text{ A}$$

$$R_3 = 20 \text{ }\Omega$$

$$U_3 = 8 \text{ V}$$

$$R_4 = 10 \text{ }\Omega$$

Determine the open circuit voltage between A and B using the principle of superposition.

Tips

- What do the individual circuits look like, by which the effects of the individual sources can be calculated?
Which equivalent resistor must be used to replace a current or voltage source when calculating the individual effects?
- Where are the open-circuit voltages applied when looking at the individual

components?

Solution

First, the individual circuits must be created, from which the effect of the individual sources between points A and B can be determined.

(Voltage) source U_1

- substitute the current source I_2 with a short-circuit
- substitute the voltage source U_3 with an open circuit

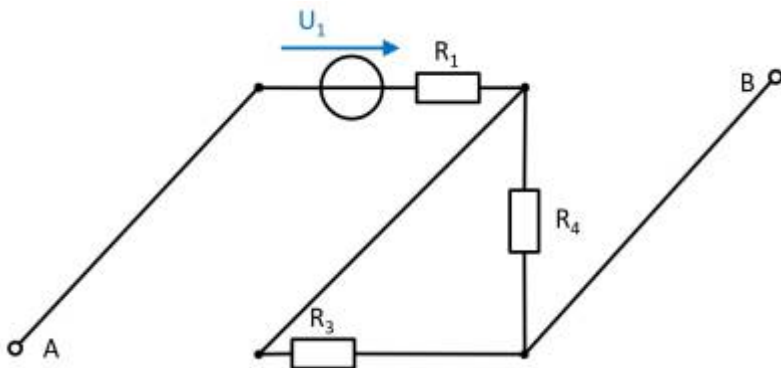

The components can be moved in order to understand the circuit s bit better.

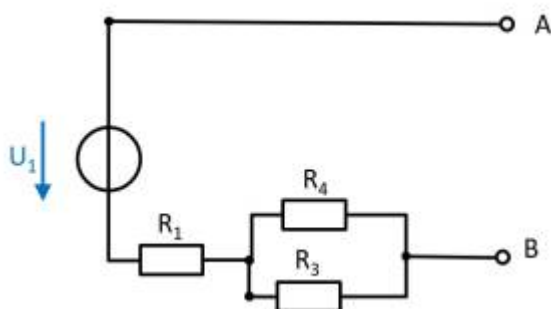

For the open circuit, no current is flowing through any resistor. Therefore, the effect is:
 $U_{AB,1} = U_1$

(current) source I_2

- substitute the voltage source U_1 with an open circuit
- substitute the voltage source U_3 with an open circuit

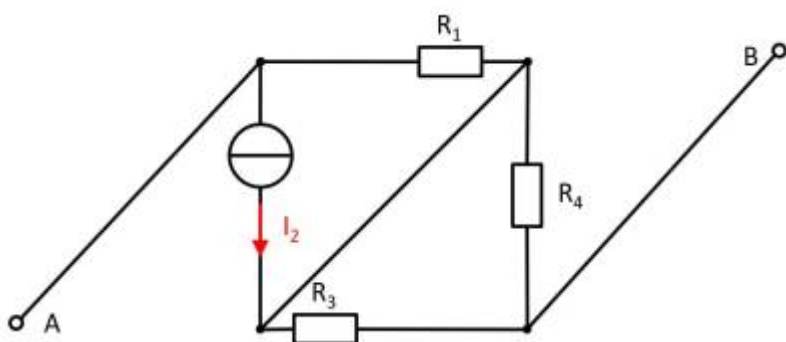

Also here, the components can be shifted for a better understanding:

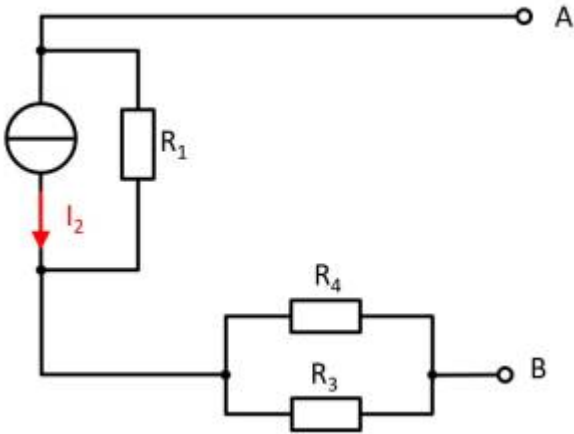

Here, the current source I_2 creates a voltage drop $U_{AB,2}$ on the resistor R_2 :
 $U_{AB,2} = - R_2 \cdot I_2$

(Voltage) source U_3

- substitute the voltage source U_1 with an open circuit
- substitute the current source I_2 with a short-circuit

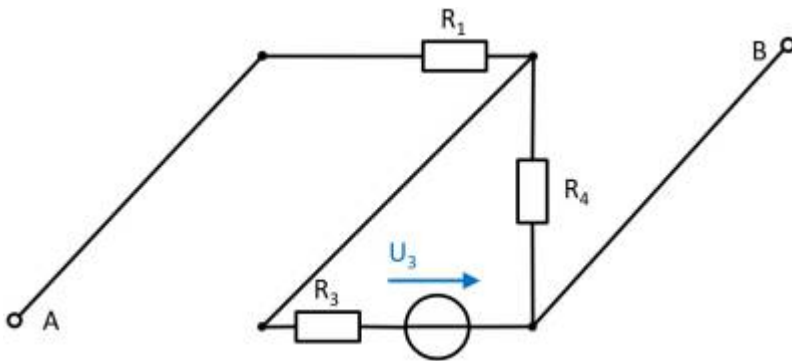

Again, rearranging the circuit might help for an understanding:

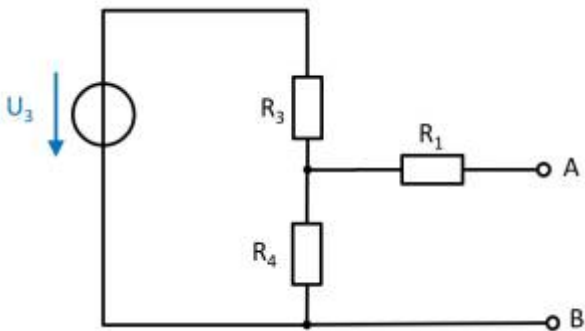

In this case, between the unloaded outputs A and B there will be an unloaded voltage divider given by R_3 and R_4 . On R_1 there is no voltage drop since there is no current flow out of the unloaded outputs.

Therefore:

$$U_{AB,3} = \frac{R_4}{R_3 + R_4} \cdot U_3$$

resulting voltage

$$U_{\text{AB}} = U_1 - R_1 \cdot I_2 + \frac{R_4}{R_3 + R_4} \cdot U_3$$

Final value

$$U_{\text{AB}} = 2 \text{ V} - 5 \Omega \cdot 1 \text{ A} + \frac{10 \Omega}{20 \Omega + 10 \Omega} \cdot 8 \text{ V} \\ \rightarrow U_{\text{AB}} = -0.333 \text{ V}$$

Exercise 4.5.3 -Variation: open circuit voltage via superposition (exam task, approx. 12 % of a 60-minute exam, WS2020)

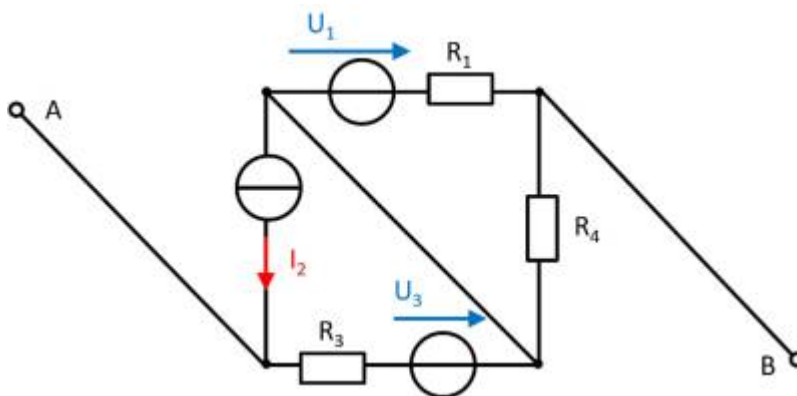

A circuit is given with the following parameters

$$R_1 = 5 \Omega$$

$$U_1 = 2 \text{ V}$$

$$I_2 = 1 \text{ A}$$

$$R_3 = 20 \Omega$$

$$U_3 = 8 \text{ V}$$

$$R_4 = 10 \Omega$$

Determine the open circuit voltage between A and B using the principle of superposition.

Solution

Case 1: For this case is $I_2 = 0 \text{ A}$ and $U_3 = 0 \text{ V}$. The voltage is at R_4 .

$$U_{\text{AB},1} = \frac{R_4}{R_1 + R_4} U_1 = \frac{10\ \Omega}{5\ \Omega + 10\ \Omega} \cdot 2\ \text{V} = 1.33\ \text{V}$$
 Case 2: For this case is $U_1 = 0\ \text{V}$ and $U_3 = 0\ \text{V}$. The voltage is at R_3 .

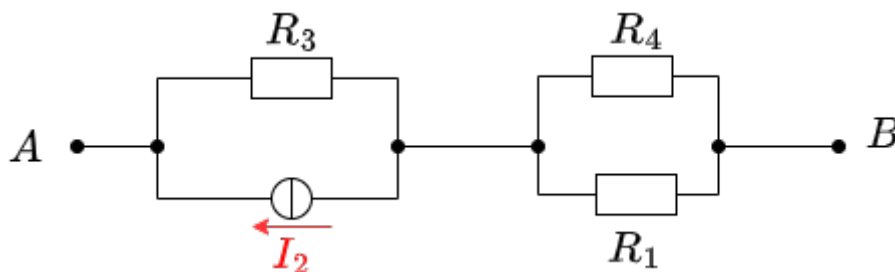

$$U_{\text{AB},2} = R_3 I_2 = 20\ \Omega \cdot 1\ \text{A} = 20\ \text{V}$$
 Case 3: For this case is $U_1 = 0\ \text{V}$ and $I_2 = 0\ \text{A}$. The voltage comes from the source U_3 .



$$U_{\text{AB},3} = 8 \text{ V}$$
 Superposition means adding the voltages of all three cases.

$$U_{\text{AB}} = U_{\text{AB},1} + U_{\text{AB},2} + U_{\text{AB},3} = 1.33 \text{ V} + 20 \text{ V} + 8 \text{ V}$$

Final value

$$U_{\text{AB}} = 29.333... \text{ V} \rightarrow 29.3 \text{ V}$$

Exercise 4.5.4 - Variation: open circuit voltage via superposition (exam task, approx. 12 % of a 60-minute exam, WS2020)

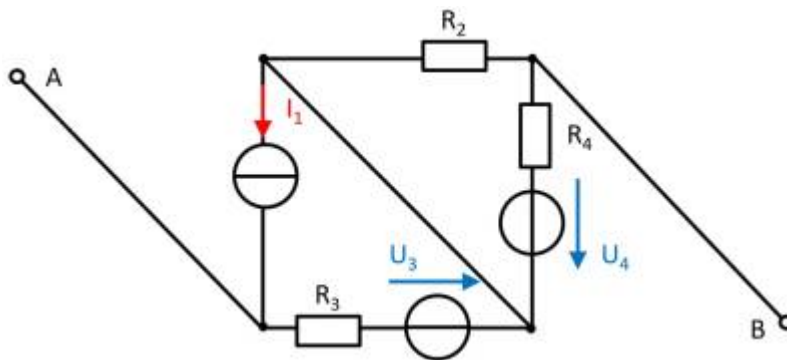

A circuit is given with the following parameters

$$I_1 = 2 \text{ A}$$

$$R_2 = 5 \text{ } \Omega$$

$$R_3 = 20 \text{ } \Omega$$

$$U_3 = 1 \text{ V}$$

$$R_4 = 10 \text{ } \Omega$$

$$U_4 = 3 \text{ V}$$

Determine the open circuit voltage between A and B using the principle of superposition.

Embedded resources

Introduction to Superposition Method (starting from 34:24, Before there are other methods not covered here)

1)

$x=x+1$ is not meant mathematically, but procedurally as in the programming language C

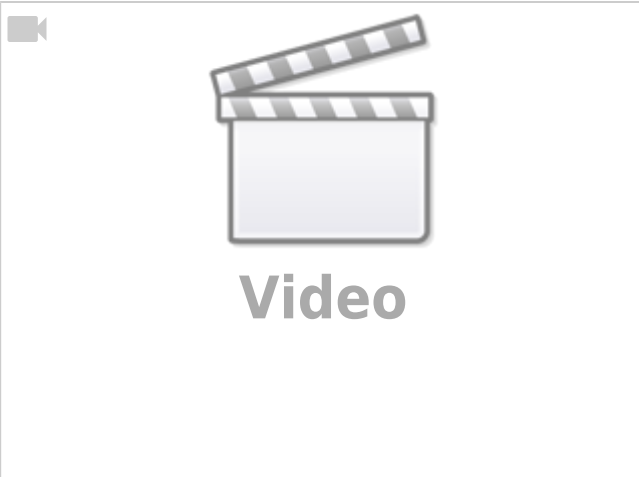

From:

<https://mexle.te.hs-heilbronn.de/> - MEXLE Wiki

Permanent link:

https://mexle.te.hs-heilbronn.de/electrical_engineering_and_electronics_1/block08?rev=1768046512

Last update: **2026/01/10 13:01**

