

# 2 Simple DC circuits

## Student Group

First Name	Surname	Matrikel Nr.

## Table of Contents

- 2. Simple DC circuits** ..... 3
- 2.1 ideal components** ..... 3
  - goals ..... 3
  - Consumer ..... 3
  - Sources ..... 4
  - wire connection ..... 5
- 2.2 Reference-arrow Systems, sign Convention and first consideration of a DC circuit** ..... 5
  - Goals ..... 6
  - Sign and Arrow Systems ..... 6
    - Generator Reference Arrow System / Active sign convention ..... 6
    - Load Reference Arrow System ..... 6
    - Note: ..... 7
- 2.3 Nodes, Branches and Loops** ..... 8
  - Goals ..... 8
  - Simplifications ..... 10
    - Exercise 2.3.1 Branches and Nodes ..... 11
    - Exercise 2.3.2 Branches and Nodes (with explanation) ..... 11
    - Exercise 2.3.3 Simplifications of circuits ..... 11
- 2.4 Kirchhoff's circuit laws** ..... 12
  - Goals ..... 12
  - Kirchhoff's current law ..... 12
    - Note: ..... 13
    - Parallel circuit of resistors ..... 13
      - Current divider ..... 14
      - Exercise 2.4.1 Current divider ..... 14
      - Exercise 2.4.2 two resistors ..... 14
  - Kirchhoff's voltage law ..... 15
    - Note: ..... 15

Proof of Kirchhoff's voltage law .....	15
Series circuit of resistors .....	16
Exercise 2.4.3 Three Resistors .....	16
<b>2.5 Unloaded and loaded voltage divider</b> .....	16
The unloaded voltage divider .....	17
Goals .....	17
Exercise 2.5.1 unloaded voltage divider .....	18
The loaded voltage divider .....	18
Exercise 2.5.2 loaded voltage divider I .....	19
Exercise 2.5.3 loaded voltage divider II .....	20
Exercise 2.5.4 Application of the loaded voltage divider - motor .....	20
Exercise 2.5.5 Examples of the calculation of loaded voltage dividers .....	21
Exercise 2.5.6 Example of a loaded voltage divider: Explanation without calculation (German) .....	21
<b>2.6 Star and Delta Circuits</b> .....	21
Goals .....	22
Delta circuit .....	23
Star circuit .....	23
Y- $\Delta$ -Transformation .....	24
Notice: .....	24
Exercise 2.6.1 Application of delta-Y conversion .....	25
Exercise 2.6.2 more difficult exercise with Y-delta transformation (German) .....	25
<b>2.7 Circuits with multiple resistors</b> .....	26
Goals .....	26
simple example .....	26
Example with $\Delta$ -Y-Transformation .....	27
Example with symmetries in the circuit .....	28
Exercise 2.7.1 Circuit Simplification Exercise I .....	28
Exercise 2.7.2 Circuit Simplification Exercise II + III .....	29
Exercise 2.7.3 Circuit Simplification Exercise IV .....	29
Exercise 2.7.4 Circuit Simplification Exercise V .....	30
Exercise 2.7.5 Circuit Simplification Exercise V .....	30
Exercise 2.7.6 Circuit Simplification VI Exercise .....	30
Exercise 2.7.7 Simplifying Circuits (exam task, about 8% of a 60-minute exam, WS2020) .....	31
Exercise 2.7.8: Simplifying Circuits II (written exam task, approx 8% of a 60-minute written exam, WS2020) .....	32
Exercise 2.7.9 - Variation: Simplifying Circuits II (written exam task, approx 8% of a 60- minute written exam, WS2020) .....	35
Exercise 2.7.10 - Variation: Simplifying Circuits III (written exam task, approx 8% of a 60- minute written exam, WS2020) .....	36
other Exercises .....	36

## 2. Simple DC circuits



Fig. 1: Example of a circuit

So far, only simple circuits consisting of a source and a load connected by wires have been considered.

In the following, more complicated circuit arrangements will be analysed. These initially contain only one source, but several lines and many ohmic loads (cf. [figure 1](#)).

### 2.1 ideal components

#### goals

After this lesson you should:

1. Know the representation of ideal current and voltage sources in the U-I diagram.
2. Know the internal resistance of ideal current and voltage sources.
3. Know the symbol of ideal current and voltage sources.
4. Know the properties of ideal resistance and ideal connection.

Every electrical circuit consists of three elements:

1. **Consumers:** consumers convert electrical energy into energy that is not purely electrical.  
e.g.
  1. into electrostatic energy (capacitor)
  2. into magnetostatic energy (magnet)
  3. into electromagnetic energy (LED, light bulb)
  4. into mechanical energy (loudspeaker, motor)
  5. into chemical energy (charging an accumulator)
2. **sources (generators):** sources convert energy from another form of energy into electrical energy. (e.g. generator, battery, photovoltaic).
3. **wires (interconnections):** the wires of interconnection lines link consumers to sources.

These elements will be considered in more detail below.

#### Consumer

- The colloquial term 'consumer' in electrical engineering stands for an electrical consumer - i.e. a component which converts electrical energy into another form of energy.
- A resistor is often also referred to as a consumer. In addition to pure ohmic consumers, however, there are also ohmic-inductive consumers (e.g. coils in a motor) or ohmic-capacitive

consumers (e.g. various power supplies using capacitors at the output). Correspondingly the equation “consumer is a resistor” is wrong.

- Current-voltage characteristics (vgl. figure 2)
  - Current-voltage characteristics of a load always run through the origin, because without current there is no voltage and vice versa.
  - Ohmic loads have a linear current-voltage characteristic which can be described by a single numerical value.  
The slope in the  $I-U$ -characteristic is the conductance:  $I = G \cdot U = \frac{U}{R}$

Fig. 2: Examples of current-voltage characteristics



## Sources

Ideal Sources



Fig. 3: ideal voltage source

Fig. 4: ideal current source



- Sources act as generators of electrical energy
- A distinction is made between ideal and real sources.  
The real sources are described in the following chapter “[non-ideal sources and two pole networks](#)”.

The **ideal voltage source** generates a defined constant output voltage  $U_q$  (in German often  $U_q$  for Quellenspannung). In order to maintain this voltage, it can supply any current. The current-voltage characteristic also represents this (see [figure 3](#)).

The circuit symbol shows a circle with two terminals. In the circuit, the two terminals are short-circuited.

Another circuit symbol shows the negative terminal of the voltage source as a “thick minus symbol”, the positive terminal is drawn wider.

The **ideal current source** produces a defined constant output current  $I_q$  (in German often  $I_q$  for Quellenstrom). For this current to flow, any voltage can be applied to its terminals. The current-voltage characteristic also represents this (see [figure 4](#)).

The circuit symbol shows again a circle with two connections. This time the two connections are left open in the circle and a line is drawn perpendicular to them.

## wire connection

- The ideal connection line is resistance-free and transmits current and voltage instantaneously.
- Real existing influences (e.g. voltage drop) of connections are considered via separately drawn components (e.g. ohmic resistance).

## 2.2 Reference-arrow Systems, sign Convention and first consideration of a DC circuit

## Goals

After this lesson you should:

1. Be able to apply and distinguish between the producer and consumer reference arrow systems (German: Erzeuger-Pfeilsystem und Verbraucher-Pfeilsystem).
2. similarly be able to use passive and active sign convention.

In the chapter [1. Preparation and Proportions](#) the direction of conventional current and voltages has already been discussed. Unfortunately, with meshed networks it is often not clear ahead of the calculation in which direction the conventional sense of direction of all currents and voltages runs.

In [figure 5](#) such a meshed net is shown. In this circuit a switch  $S_1$  and a current  $I_2$  are marked. Once the state of the switch is swapped, the direction of the current changes.

Fig. 5: Example of a circuit

## Sign and Arrow Systems

For the direction of the arrows different conventions are available. Here (and quite often in Germany) the [convention of power engineering](#) is used. This convention is

### Generator Reference Arrow System / Active sign convention

Fig. 6: Generator Arrow System

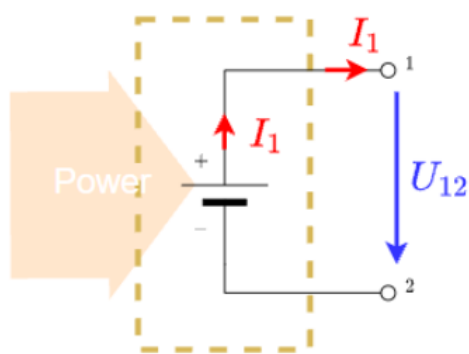

With **sources** (or generators), energy is taken from the environment and made available to the circuit. For generators, the arrowfoot of the current is attached to the arrowhead of the voltage. Voltage and current arrows are antiparallel ( $\uparrow$

Fig. 7: Load Arrow System

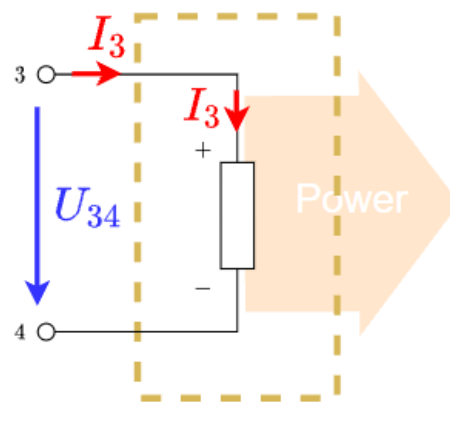

### Load Reference Arrow System

In the case of **consumers**, energy is taken from the circuit and made available to the environment. For consumers, the arrowfoot or arrowhead of the current and voltage

\downarrow\$).

Similarly, the active sign convention for one component states: The current enters the component on the more negative terminal. Or vice versa: The current exits the component on the positive terminal.

Both expressions “generator arrow system” and “active sign convention” come to the same result, when drawing the arrows.

For generators holds:  $P_1 = U_{12} \cdot I_1 \stackrel{!}{>} 0$

The power transfer from the environment to the power system via the generator or the generator arrow system is calculated positively.

are related. Voltage and current arrows are parallel ( $\uparrow$ ). Here we have to use the passive sign convention: The current enters the component on the more positive terminal. Or vice versa: The current exits the component on the negative terminal.

Both expressions again come to the same result, when drawing the arrows.

For consumers, the following holds:

$P_3 = U_{34} \cdot I_3 \stackrel{!}{>} 0$

The power transfer from the power system to the environment via the consumer or the consumer arrow system is also calculated positively.

### Note:

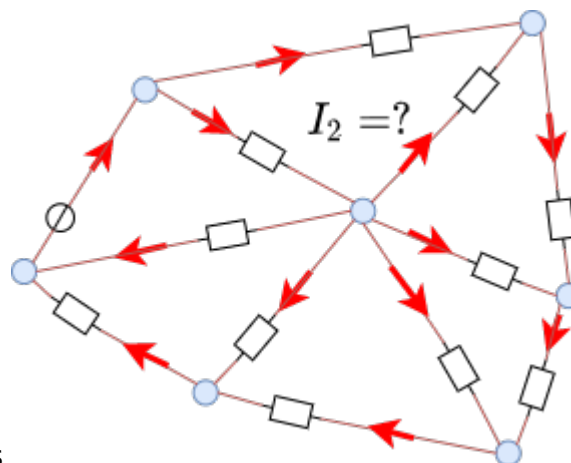

Fig. 8: Reference arrows

- **Before the calculation**, the reference arrows for currents and voltages are set arbitrarily, with the following conditions:
  - the active sign convention / generator arrow system is used for all sources (e.g. all voltage and current sources): the current is antiparallel to the voltage arrow.
  - the passive sign convention / motor arrow system is used for all consumers (e.g. all passives like resistors, capacitors, inductors, diodes etc.): the current is parallel to the voltage arrow.
  - for loads, where the direction of the power is not known, the motor arrow system is recommended (e.g. passives, in case what these are part of a machine, like inductors of a motor)

- **After the calculation** means
  - $I > 0$ : The reference arrow reflects the conventional directional sense of the current
  - $I < 0$ : The reference arrow points in the opposite direction to the conventional directional sense of the current
- Reference arrows of the current are drawn **in** the wire if possible.

The reference arrow system (in the clip '+' and '-' is shown in the component terminal. We will instead use voltage arrows from plus to minus)



## 2.3 Nodes, Branches and Loops

Explanation of the different network structures  
(Graphs and trees are only needed in later chapters) nodes



### Goals

After this lesson you should:

1. Be able to identify the nodes, branches and loops in a circuit.
2. Be able to use them to make a circuit clearer.

Fig. 9: circuitry and mesh



Fig. 10: nodes, branches and loops



Electrical circuits typically have the structure of networks. Networks consist of two elementary structural elements:

1. **Branches** (German: Zweige): Connections between two nodes.
2. **Node** (German: Knoten): Connection "point" of several branches.

Please note in the case of electrical circuits, we will use the following definition:

1. **Branches** contain at least one component.
2. **Nodes** connect more than two branches. Since the wire in a circuit diagram is an ideal conductor, all connected wires to a node are at the same voltage level. Therefore the node in the circuit diagram can also be spatially extended by the wires.

Sometimes there is a differentiation between "simple nodes" (only connecting 2 branches) and "principal nodes" (connecting more than 2 branches). We will in the following often only mark the connection of more than two branches with a node.

Branches in electrical networks are also called two-pole. Their behaviour is described by current-voltage characteristics and explained in more detail in the chapter [non-](#)

## [ideal\\_sources\\_and\\_two\\_pole\\_networks](#) .

In addition, another term is to be explained:

A **loop** is a closed path in the loop. This means that a loop begins and ends at the same node and runs over at least one further node.

Since a voltmeter can also be present as a component between two nodes, it is also possible to close a loop by a drawn voltage arrow (cf.  $U_1$  in [figure 10](#)).

A loop which does not contain other (smaller) loops is called a mesh.

Please keep in mind, that usually the entire behaviour of networked circuits almost always changes when a change occurs in one branch or at one node. This is in contrast to other cause-effect relationships, but comparable to changes in other larger networks, e.g. a traffic jam in the road network, due to which other roads experience a higher load. For electrical engineering, this means that in the case of changing circuits, the focus is often on determining the interrelationships (formulas, current-voltage characteristics) and not on a single numerical value.

## Simplifications



Fig. 11: Example of circuit conversion

With the knowledge of nodes, branches and meshes, circuits can be simplified. Circuits can be reshaped arbitrarily as long as all branches remain at the same nodes after reshaping. The [figure 11](#) shows how such a transformation is possible.

For practical tasks, repeated trial and error can be useful. It is important to check afterwards that the same components are connected to each node as before the transformation.

Further examples can be found in the following video



### Exercise 2.3.1 Branches and Nodes

Fig. 12: Branches and Nodes



For the markings in the circuits in [figure 12](#) indicate whether it is a branch, a node, or neither.

### Exercise 2.3.2 Branches and Nodes (with explanation)



### Exercise 2.3.3 Simplifications of circuits

Fig. 13: more Branches and Nodes

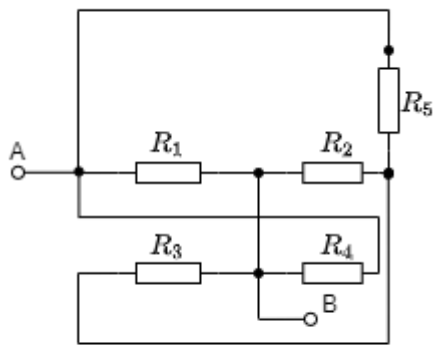

(1)

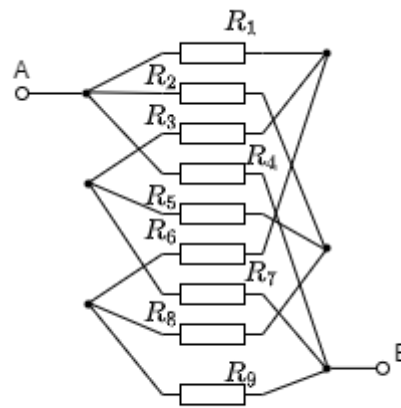

(2)

Simplify the circuits in [figure 13](#).

## 2.4 Kirchhoff's circuit laws

### Kirchhoff's circuit laws

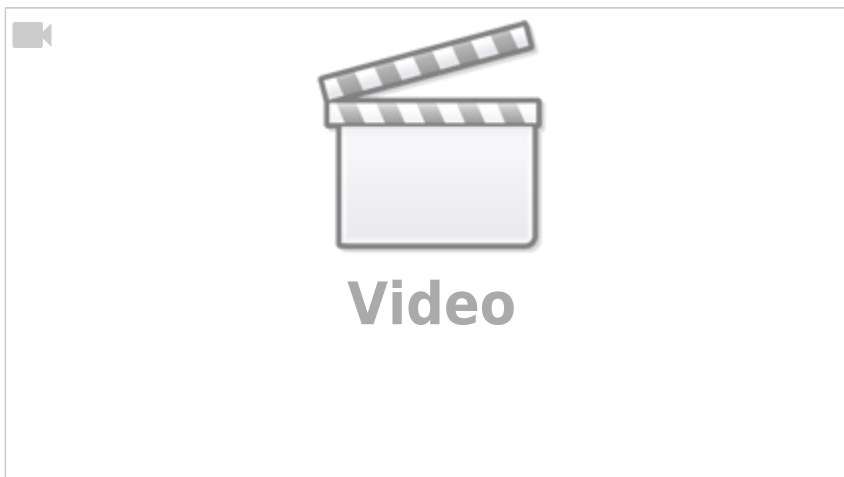

#### Goals

After this lesson you should: Know and be able to apply Kirchhoff's circuit laws (Kirchhoff's current law and Kirchhoff's voltage law).

### Kirchhoff's current law

The Kirchhoff's current law (Kirchhoff's first law, Kirchhoff's nodal rule, in German: Knotensatz) formulates in the language of mathematics the experience that no charge "accumulations" occur in electrical wires. This is of particular relevance at a network node ([figure 14](#)). To formulate the equation at this node, the reference arrows of the currents are all set in the same way. That means: all point away from or towards the node.

**Note:**



Fig. 14: Kirchhoff's current law

The sum of all currents flowing from the nodes must be zero.

$$\boxed{I_1 + I_2 + I_3 + \dots + I_n = \sum_{x=1}^n I_x = 0}$$

From now on, the following definition applies:

- Currents whose current arrows point towards the node are added in the calculation.
- Currents whose current arrows point away from the node are subtracted in the calculation.



Fig. 15: Parallel circuit

**Parallel circuit of resistors**

From the Kirchhoff's current law, the total resistance for resistors connected in parallel can be derived (figure 15):

Since the same voltage  $U_{ab}$  is dropped across all resistors, using the Kirchhoff's current law:

$$\frac{U_{ab}}{R_1} + \frac{U_{ab}}{R_2} + \dots + \frac{U_{ab}}{R_n} = \frac{U_{ab}}{R_{\text{substitute}}}$$

$$\rightarrow \frac{1}{R_1} + \frac{1}{R_2} + \dots + \frac{1}{R_n} = \frac{1}{R_{\text{substitute}}} = \sum_{x=1}^n \frac{1}{R_x}$$

Thus, for resistors connected in parallel, the equivalent conductance  $G_{eq}$  (German: Ersatzleitwert) is the sum of the individual conductances:  $G_{eq} = \sum_{x=1}^n G_x$

In general: the equivalent resistance of a parallel circuit is always smaller than the smallest

resistance.

Especially for two parallel resistors  $R_1$  and  $R_2$  applies:  $R_{eq} = \frac{R_1 \cdot R_2}{R_1 + R_2}$

## Current divider

Derivation of the current divider with examples



The current divider rule can also be derived from the Kirchhoff's current law.

This states that, for resistors  $R_1, \dots, R_n$  their currents  $I_1, \dots, I_n$  behave just like the conductances  $G_1, \dots, G_n$  through which they flow.

$$\frac{I_1}{I_g} = \frac{G_1}{G_g}$$

$$\frac{I_1}{I_2} = \frac{G_1}{G_2}$$

### Exercise 2.4.1 Current divider

Fig. 16: Current divider

In the simulation in [figure 16](#) a current divider can be seen. The resistances are just inversely proportional to the currents flowing through it.

1. What currents would you expect in each branch if the input voltage were lowered from  $5V$  to  $3.3V$ ? After thinking about your result, you can adjust the Voltage (bottom right of the simulation) accordingly by moving the slider.
2. Think about what would happen if you flipped the switch before you flipped the switch. After you flip the switch, how can you explain the current in the branch?

### Exercise 2.4.2 two resistors

Two resistors of  $18\Omega$  and  $2\Omega$  are connected in parallel. The total current of the resistors is  $3A$ .

Calculate the total resistance and how the currents is split to the branches.

## Kirchhoff's voltage law

Also the Kirchhoff's voltage law (also called: Kirchhoff's second law, or loop law) describes in mathematical language another practical experience: Between two points \$1\$ and \$2\$ of a network there is only one potential difference. Thus the potential difference is in particular independent of the way a network is traversed between the two points \$1\$ and \$2\$. This can be described by considering the meshes.

### Note:

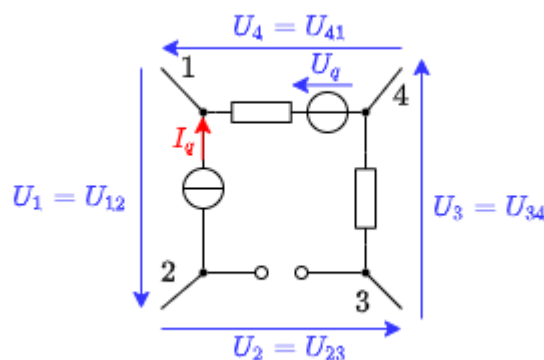

Fig. 17: loop law

In any mesh of an electrical circuit, the sum of all voltages is always zero (figure 17):

$$\boxed{U_{\{1\}} + U_{\{2\}} + \dots + U_{\{n\}} = \sum_{x=1}^n U_x = 0}$$

To calculate this, a convention for the loop direction must be specified. Theoretically this can be chosen arbitrarily. In practice, often a specific direction (e.g. [clockwise](#)) is used.

Independently, the following specification always applies: For voltage drop the inverse sign of a voltage rise has to be taken into account. For example:

- Voltages, whose voltage arrows point in the direction of circulation are added in the calculation.
- Voltages, whose voltage arrows point against the direction of rotation are subtracted in the calculation.

## Proof of Kirchhoff's voltage law

If one expresses the voltage in [figure 17](#) dby the potentials in the nodes, we get:  $U_{\{12\}} = \varphi_1 - \varphi_2$

$$U_{\{23\}} = \varphi_2 - \varphi_3$$

$$U_{\{34\}} = \varphi_3 - \varphi_4$$

$$U_{\{41\}} = \varphi_4 - \varphi_1$$

If these voltages are added, this leads to Kirchhoff's voltage law.

$$U_{12} + U_{23} + U_{34} + U_{41} = 0$$

### Series circuit of resistors



Fig. 18: series circuit

Using Kirchhoff's voltage law, the total resistance of a series circuit (in German: Reihenschaltung, see [FigNo13](#)) can be easily determined:

$$U_1 + U_2 + \dots + U_n = U_g$$

$$R_1 \cdot I_1 + R_2 \cdot I_2 + \dots + R_n \cdot I_n = R_{\text{ersatz}} \cdot I$$

Since in series circuit the current through all resistors must be the same - i.e.  $I_1 = I_2 = \dots = I$  - it follows that:

$$R_1 + R_2 + \dots + R_n = R_{\text{eq}} = \sum_{x=1}^n R_x$$

In general: The equivalent resistance of a series circuit is always greater than the greatest resistance..

### Exercise 2.4.3 Three Resistors

Three equal resistors of  $20\text{k}\Omega$  each are given.

Which values are realizable by arbitrary interconnection of one to three resistors?

## 2.5 Unloaded and loaded voltage divider

Why are voltage dividers important? (a cutout from 0:00 to 10:56 from a full video of EEVblog, starting from 17:00 there is also a nice example for troubles with voltage dividers..)



## The unloaded voltage divider

### Goals

After this lesson you should be able to:

1. to distinguish between the loaded and unloaded voltage divider.
2. to describe the differences between loaded and unloaded voltage dividers.

Fig. 21: unloaded voltage divider

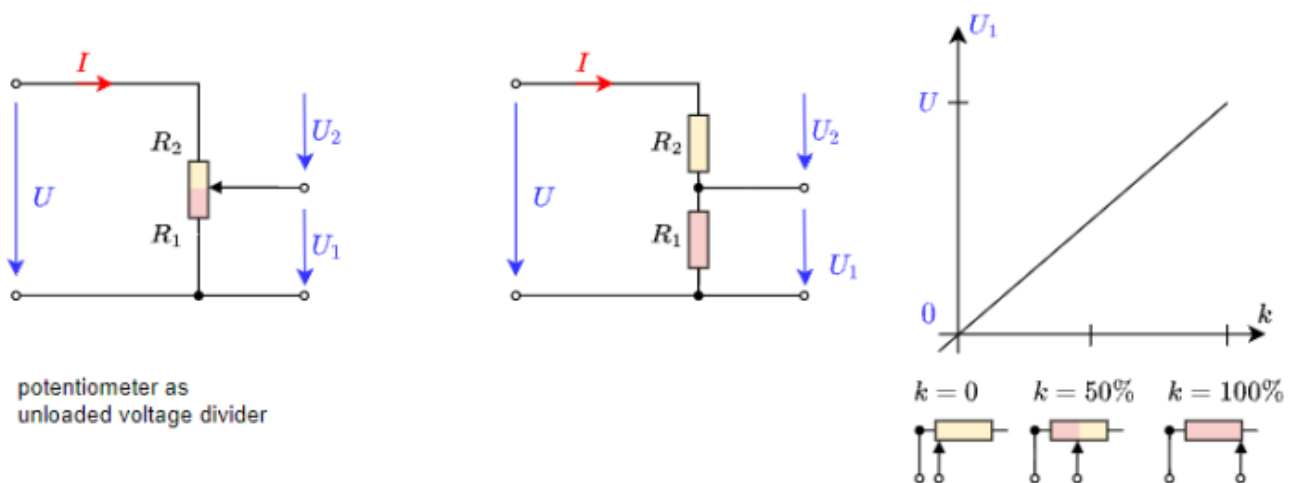

Especially the series circuit of two resistors  $R_1$  and  $R_2$  shall be considered now. This situation occurs in many practical applications (e.g. [potentiometer](#)). In [figure 21](#) this circuit is shown.

Via the Kirchhoff's voltage law we get

$$\boxed{\left\{ \frac{U_1}{U} \right\} = \left\{ \frac{R_1}{R_1 + R_2} \right\}}$$

The ratio  $k = \left\{ \frac{R_1}{R_1 + R_2} \right\}$  also corresponds to the position on a potentiometer.

### Exercise 2.5.1 unloaded voltage divider

Fig. 22: unloaded voltage divider

In the simulation in [figure 22](#) an unloaded voltage divider in the form of a potentiometer can be seen. The ideal voltage source provides  $5V$ . The potentiometer has a total resistance of  $1k\Omega$ . In the configuration shown, this is divided out to  $500\Omega$  and  $500\Omega$ .

1. What voltage  $U_{out}$  would you expect if the switch were closed? After thinking about your result, you can check it by closing the switch.
2. First think about what would happen if you would change the distribution of the resistors by moving the wiper ("intermediate terminal")? You can check your assumption by using the slider at the bottom right of the simulation.
3. At which position do you get a  $U_{out} = 3.5V$ ?

### The loaded voltage divider

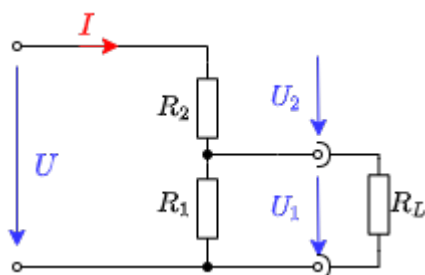

Fig. 23: loaded voltage divider

If - in contrast to the above-mentioned, unloaded voltage divider - a load  $R_L$  is connected to the output terminals ([figure 23](#)), this load influences the output voltage.

A circuit analysis yields:

$$U_1 = U \cdot \frac{R_1}{R_1 + R_2 + \frac{R_1 R_2}{R_L}}$$

or on a potentiometer with  $k$  and the sum of resistors  $R_s = R_1 + R_2$ :

$$U_1 = U \cdot \frac{k}{1 + k(1-k) \cdot \frac{R_s}{R_L}}$$

Fig. 24: Voltage curve of the loaded voltage divider



figure 24 shows the ratio of the output voltage  $U_1$  to the input voltage  $U$  (y-axis), in relation to the ratio  $k = \frac{R_1}{R_1 + R_2}$ . In principle, this is similar to figure 21, but here it has another dimension: multiple graphs are plotted. These differ by the ratio  $\frac{R_s}{R_L}$ .

What does this diagram tell us? This shall be investigated by an example. First, assume an unloaded voltage divider with  $R_2 = 4 \text{ k}\Omega$  and  $R_1 = 6 \text{ k}\Omega$ , and an input voltage of  $10\text{V}$ . Thus  $k = 0.6$ ,  $R_s = 10 \text{ k}\Omega$  and  $U_1 = 6\text{V}$ . Now this voltage divider is loaded with a load resistor. If this is at  $R_L = R_1 = 10 \text{ k}\Omega$ ,  $k$  reduces to about  $0.48$  and  $U_1$  reduces to  $4.8\text{V}$  - so the output voltage drops. For  $R_L = 4 \text{ k}\Omega$ ,  $k$  becomes even smaller to  $k = 0.375$  and  $U_1 = 3.75\text{V}$ . If the load  $R_L$  is only one tenth of the resistor  $R_s = R_1 + R_2$ , the result is  $k = 0.18$  and  $U_1 = 1.8\text{V}$ . The output voltage of the unloaded voltage divider ( $6\text{V}$ ) thus became less than one third.

What is the practical use of the (loaded) voltage divider?

Here some examples:

- Voltage dividers are in use for controlling the output of power supply IC's (see [Voltage Dividers in Power Supplies](#)). In order not to create a loaded voltage divider, a range for the resistance is given here.
- Another "invisible" voltage divider is for example in the electrical system of a car. As we will learn in the next chapters, voltage supplies have in internal resistance (and therefore batteries, too). The other consumer in the car also represent a resistance. By this, the electrical system states an unloaded voltage divider. Given another, additional low-resistance load (e.g. the spark of the starter system) one can understand that there will be a voltage drop when starting the car.

### Exercise 2.5.2 loaded voltage divider I

Determine from the circuit in figure 23 the equation  $U_1 = \frac{k \cdot U}{1 + k \cdot (1-k) \cdot \frac{R_s}{R_L}}$  where  $k = \frac{R_1}{R_1 + R_2}$  and  $R_s = R_1 + R_2$ .

### Exercise 2.5.3 loaded voltage divider II

Fig. 25: loaded voltage divider

In the simulation in [figure 25](#) a loaded voltage divider in the form of a potentiometer can be seen. The ideal voltage source provides  $5\text{V}$ . The potentiometer has a total resistance of  $1\text{k}\Omega$ . In the configuration shown, this is divided out to  $500\ \Omega$  and  $500\ \Omega$ . The load resistance has  $R_L = 1\text{k}\Omega$ .

1. What voltage  $U_{\text{OUT}}$  would you expect if the switch were closed? This is where you need to do some math! After you calculated your result, you can check it by closing the switch.
2. At which position of the wiper you get  $3.5\text{V}$  as an output? Determine the result first by means of a calculation. Then check it by moving the slider at the bottom right of the simulation.

### Exercise 2.5.4 Application of the loaded voltage divider - motor

Fig. 26: Skizze des Aufbaus

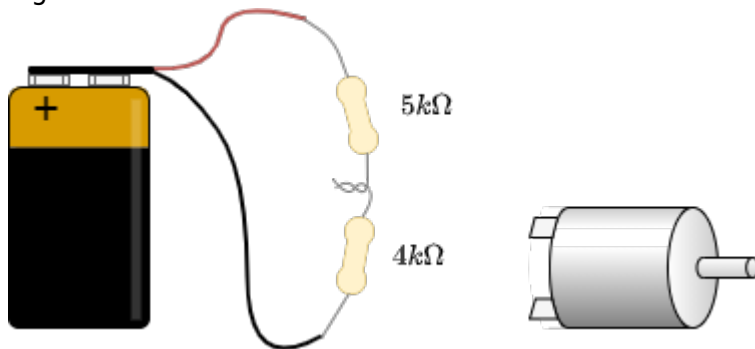

You wanted to test a micromotor for a small robot. Using the maximum current and the internal resistance ( $R_M = 5\ \Omega$ ) you calculate that this can be operated with a maximum of  $U_{M,\text{max}} = 4\text{V}$ . A colleague said that you can get  $4\text{V}$  using the setup in [figure 26](#) from a  $9\text{V}$  block battery.

1. First, calculate the maximum current  $I_{M,\text{max}}$  of the motor.
2. Draw the corresponding electrical circuit with the motor connected as an ohmic resistor.
3. At the maximum current, the motor should be able to deliver a torque of  $M = 100\text{mNm}$ . What torque would the motor deliver if you implement the setup like this? (Assumption: The torque of the motor increases proportionally to the motor current).
4. What might a setup with a potentiometer look like that would actually allow you to set a voltage between  $0.5\text{V}$  to  $4\text{V}$  on the motor? What resistance value should the potentiometer have?
5. Build and test your circuit in the simulation below. For an introduction to online simulation, see: [online circuit simulator](#).

You will essentially need the following tips for this setup:

1. Routing connections can be activated via the menu: Draw » add wire. Afterwards you have to click on the start point and then drag to the end mode.

2. Note that connections can only ever be connected at nodes. A red marked node (e.g. at the  $5\ \Omega$  resistor) indicates that it is not connected. This could be moved one grid step to the left, as there is a node point there.
3. Pressing the <ESC> key will disable the insertion of components.
4. With a right click on a component it can be copied or values like the resistor can be changed via Edit...

Fig. 27: Simulation for motor setup

### Exercise 2.5.5 Examples of the calculation of loaded voltage dividers

Exercise on the voltage divider

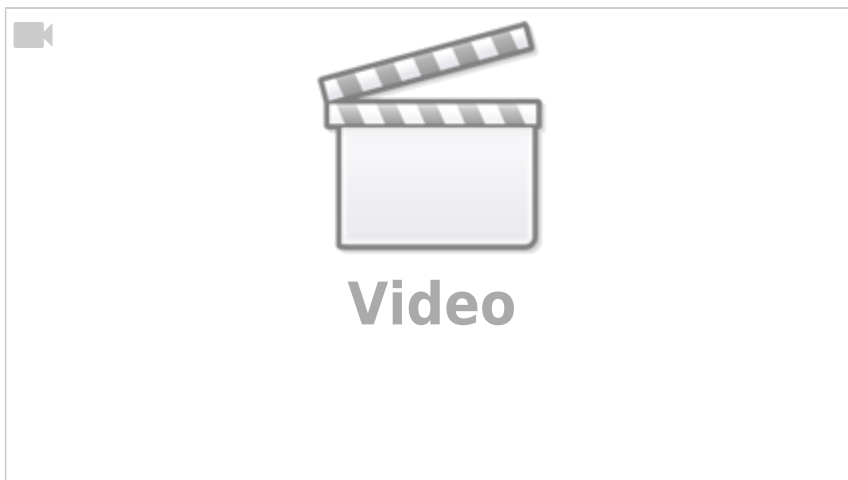

### Exercise 2.5.6 Example of a loaded voltage divider: Explanation without calculation (German)

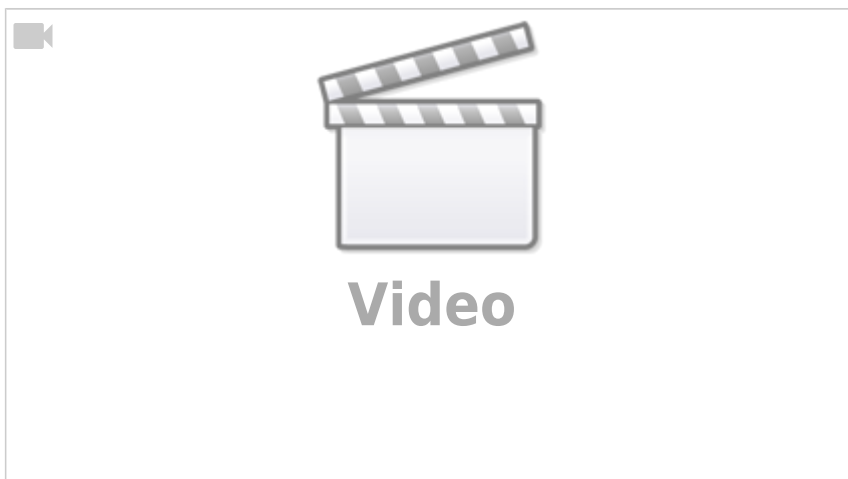

## 2.6 Star and Delta Circuits

Fig. 28: Example of a circuit



Fig. 29: Conversion of parallel circuit to series circuit

### Goals

After this lesson you should:

1. be able to convert triangular loops into a star shape (and vice versa)

At the beginning of the chapter an example of a network was shown ([figure 1](#)). Here, however, one does not come directly to the solution with the set of nodes and loops. It is visible, that there are many  $\Delta$ -shaped (or triangle-shaped) loops resp.  $Y$ -shaped (or star-shaped) nodes, see [figure 28](#). A method to calculate these will be discussed in more detail now.

First of all a summary of the previous findings: Using the node and loop rule it became clear that an equivalent resistance can be determined from a series as well as from a parallel circuit. If one considers the equivalent resistance as a black box - i.e. the internals are unknown - it could be interpreted by both types of circuit ([figure 29](#)).

Now how does this help us in the case of a  $\Delta$ -load (= triangular loop)?

Also in this case one can provide a black box. However, this should always behave in the same way as the  $\Delta$ -load, i.e. any voltages applied should produce the same currents as the known structure. In other words: The resistances measured between two terminals must be identical for the blackbox and for the known circuit.

For this purpose, the different resistances between the individual nodes  $a$ ,  $b$  and  $c$  are now to be considered, see [figure 30](#). The aim is to find out how a  $\Delta$ -load (triangular circuit) can be developed from a  $Y$ -load (star circuit) and vice versa.

Fig. 30: Star-delta transformation

Calculation of the transformation formulae: Star connection in delta connection (Alternatively in [German](#))

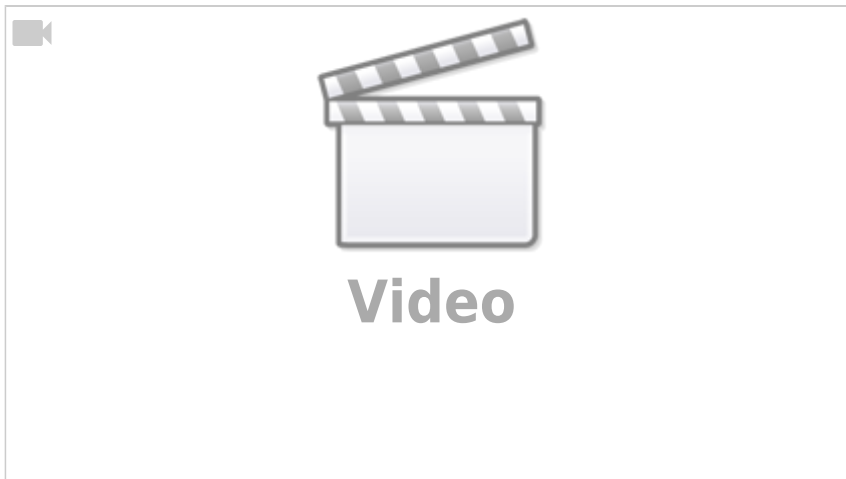

## Delta circuit

In the delta circuit, the 3 resistors  $R_{ab}$ ,  $R_{bc}$  and  $R_{ca}$  are connected in a loop. At the connection of the resistors an additional terminal is implemented.

For the resistors between two terminals (e.g.  $a$  and  $b$ ), the third one (here:  $c$ ) is considered as not connected to anything outside. This results in a parallel circuit of the direct delta resistor  $R_{ab}$  with the series connection of the other two delta resistors  $R_{ca} + R_{bc}$ :

$$R_{ab} = R_{ab} \parallel (R_{ca} + R_{bc})$$

$$R_{ab} = \frac{R_{ab} \cdot (R_{ca} + R_{bc})}{R_{ab} + (R_{ca} + R_{bc})} = \frac{R_{ab} \cdot (R_{ca} + R_{bc})}{R_{ab} + R_{ca} + R_{bc}}$$

The same applies to the other connections. This results in:

$$\begin{aligned} R_{ab} &= \frac{R_{ab} \cdot (R_{ca} + R_{bc})}{R_{ab} + R_{ca} + R_{bc}} \\ R_{bc} &= \frac{R_{bc} \cdot (R_{ab} + R_{ca})}{R_{ab} + R_{ca} + R_{bc}} \\ R_{ca} &= \frac{R_{ca} \cdot (R_{bc} + R_{ab})}{R_{ab} + R_{ca} + R_{bc}} \end{aligned} \tag{2.6.1}$$

## Star circuit

Given the idea, that the star circuit shall behave equal to the delta circuit, the resistance measured between the terminals must be similar. Also in the star circuit 3 resistors are connected, but now in a star (or  $Y$ ) shape. The star resistors are all connected with another node  $0$  in the middle:  $R_{a0}$ ,  $R_{b0}$  and  $R_{c0}$ .

Again, the procedure is the same as for the delta connection: the resistance between two terminals (e.g.  $a$  and  $b$ ) is determined, and the further terminal ( $c$ ) is considered to be open. The resistance of the further terminal ( $R_{c0}$ ) is only connected at one node. Therefore, no current flows through it - it is thus not to be considered. It results in:

$$\begin{aligned} R_{ab} &= R_{a0} + R_{b0} \\ R_{bc} &= R_{b0} + R_{c0} \\ R_{ca} &= R_{c0} + R_{a0} \end{aligned} \tag{2.6.2}$$

From equations (2.6.1) and (2.6.2) we get:

$$R_{ab} = \frac{R_{ab} \cdot (R_{ca} + R_{bc})}{R_{ab} + R_{ca} + R_{bc}}$$

$$R_{bc}^1 = R_{a0}^1 + R_{b0}^1 \tag{2.6.3}$$

$$R_{bc} = \frac{R_{bc}^1 \cdot (R_{ab}^1 + R_{ca}^1)}{R_{ab}^1 + R_{ca}^1 + R_{bc}^1} = R_{b0}^1 + R_{c0}^1 \tag{2.6.4}$$

$$R_{ca} = \frac{R_{ca}^1 \cdot (R_{bc}^1 + R_{ab}^1)}{R_{ab}^1 + R_{ca}^1 + R_{bc}^1} = R_{c0}^1 + R_{a0}^1 \tag{2.6.5}$$

Equations (2.6.3) to (2.6.5) can now be cleverly combined so that there is only one resistor on one side.

A variation is to write the formulas as  $\frac{1}{2} \cdot \left( (2.6.3) + (2.6.4) - (2.6.5) \right)$  or  $\frac{1}{2} \cdot \left( R_{ab} + R_{bc} - R_{ca} \right)$  to combine. This gives  $R_{b0}^1$

$$\begin{aligned} & \frac{1}{2} \cdot \left( \frac{R_{ab}^1 \cdot (R_{ca}^1 + R_{bc}^1)}{R_{ab}^1 + R_{ca}^1 + R_{bc}^1} + \frac{R_{bc}^1 \cdot (R_{ab}^1 + R_{ca}^1)}{R_{ab}^1 + R_{ca}^1 + R_{bc}^1} - \frac{R_{ca}^1 \cdot (R_{bc}^1 + R_{ab}^1)}{R_{ab}^1 + R_{ca}^1 + R_{bc}^1} \right) = \frac{1}{2} \cdot \left( R_{a0}^1 + R_{b0}^1 + R_{b0}^1 + R_{c0}^1 - R_{c0}^1 - R_{a0}^1 \right) \\ & \frac{1}{2} \cdot \left( \frac{R_{ab}^1 \cdot (R_{ca}^1 + R_{bc}^1)}{R_{ab}^1 + R_{ca}^1 + R_{bc}^1} + \frac{R_{bc}^1 \cdot (R_{ab}^1 + R_{ca}^1)}{R_{ab}^1 + R_{ca}^1 + R_{bc}^1} - \frac{R_{ca}^1 \cdot (R_{bc}^1 + R_{ab}^1)}{R_{ab}^1 + R_{ca}^1 + R_{bc}^1} \right) = \frac{1}{2} \cdot \left( 2 \cdot R_{b0}^1 \right) \\ & \frac{1}{2} \cdot \left( \frac{R_{ab}^1 \cdot (R_{ca}^1 + R_{bc}^1)}{R_{ab}^1 + R_{ca}^1 + R_{bc}^1} + \frac{R_{bc}^1 \cdot (R_{ab}^1 + R_{ca}^1)}{R_{ab}^1 + R_{ca}^1 + R_{bc}^1} - \frac{R_{ca}^1 \cdot (R_{bc}^1 + R_{ab}^1)}{R_{ab}^1 + R_{ca}^1 + R_{bc}^1} \right) = R_{b0}^1 \\ & \frac{1}{2} \cdot \left( \frac{2 \cdot R_{ab}^1 \cdot R_{bc}^1}{R_{ab}^1 + R_{ca}^1 + R_{bc}^1} \right) = R_{b0}^1 \end{aligned}$$

Similarly, one can resolve to  $R_{a0}^1$  and  $R_{c0}^1$ , and with a slightly modified approach to  $R_{ab}^1$ ,  $R_{bc}^1$  and  $R_{ca}^1$ .

## Y-Δ-Transformation

### Notice:

If a **delta circuit** is to be converted into a star circuit, the star resistors can be determined via:

$$\begin{aligned} & \boxed{\text{star resistance at the terminal } x} = \boxed{\text{product of the delta resistances connected with } x} \over \boxed{\text{sum of all delta resistances}} \\ & \text{therefore: } R_{a0}^1 = \frac{R_{ca}^1 \cdot R_{bc}^1}{R_{ab}^1 + R_{ca}^1 + R_{bc}^1} \quad R_{b0}^1 = \frac{R_{ab}^1 \cdot R_{bc}^1}{R_{ab}^1 + R_{ca}^1 + R_{bc}^1} \quad R_{c0}^1 = \frac{R_{bc}^1 \cdot R_{ca}^1}{R_{ab}^1 + R_{ca}^1 + R_{bc}^1} \end{aligned}$$

If a **star circuit** is to be converted into a delta circuit, the star resistors can be determined via:

$$\boxed{\text{delta resistance between the terminals } x \text{ and } y} = \left\{ \right.$$

```

\color{lightgray}{\boxed{ \color{black}{\begin{array}{l} \text{sum of all} \\ \text{products} \\ \text{between} \\ \text{varying star resistances} \end{array}} } } \over {
\color{lightgray}{\boxed{ \color{black}{\begin{array}{l} \text{star resistance} \\ \text{opposite x and y} \end{array}} } } } \\
\text{therefore:} \quad \quad \quad \quad \quad \quad \quad R_{ab}^1 \quad \&= \quad \left\{ \left\{ R_{a0}^1 \cdot R_{b0}^1 + R_{b0}^1 \cdot R_{c0}^1 + R_{c0}^1 \cdot R_{a0}^1 \right\} \over { R_{c0}^1 } \right\} \quad \parallel \quad R_{bc}^1 \quad \&= \quad \left\{ \left\{ R_{a0}^1 \cdot R_{b0}^1 + R_{b0}^1 \cdot R_{c0}^1 + R_{c0}^1 \cdot R_{a0}^1 \right\} \over { R_{a0}^1 } \right\} \quad \parallel \quad R_{ca}^1 \quad \&= \quad \left\{ \left\{ R_{a0}^1 \cdot R_{b0}^1 + R_{b0}^1 \cdot R_{c0}^1 + R_{c0}^1 \cdot R_{a0}^1 \right\} \over { R_{b0}^1 } \right\} \quad \text{end{align*}}

```

### Exercise 2.6.1 Application of delta-Y conversion

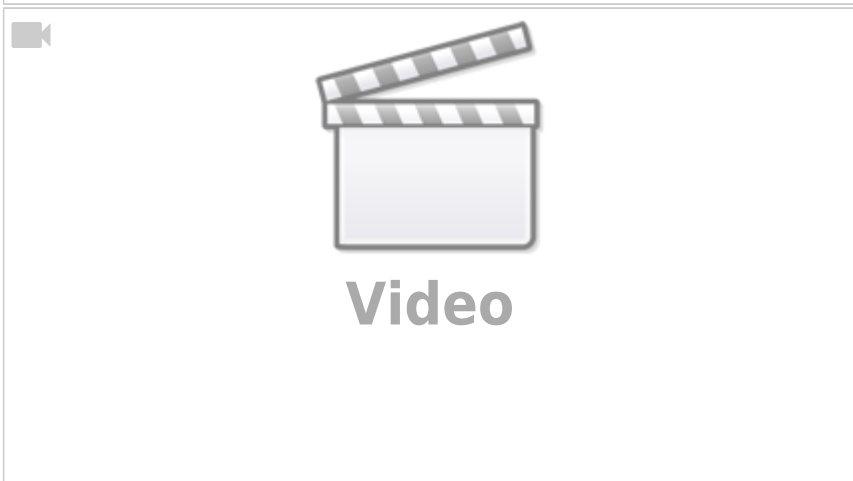
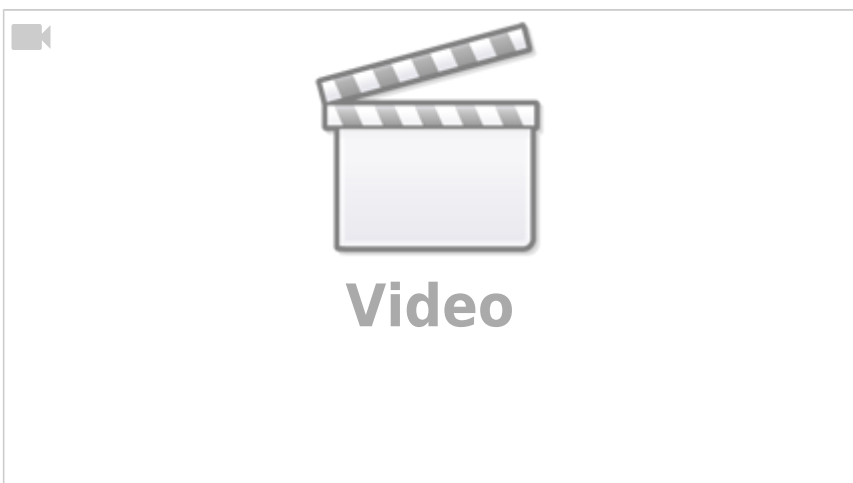

### Exercise 2.6.2 more difficult exercise with Y-delta transformation (German)



## 2.7 Circuits with multiple resistors

### Goals

After this lesson, you should:

1. be able to simplify circuits consisting only of resistors.
2. Be able to calculate the voltages and currents in circuits with a voltage source and several resistors.
3. Be able to simplify symmetrical circuits.

In this subchapter a methodology is discussed, which should help to reshape circuits. In subchapter [2.6 Star-Delta-Circuit](#) towards the end a network was already transformed in a way, that it does not contain triangular meshes any more. Now this procedure shall be systematized. Starting point are tasks, where for a resistor network the total resistance, total current or total voltage has to be calculated.

### simple example



Fig. 32: example of a circuit

An example of such a circuit is given in [figure 32](#). Here  $I_0$  is wanted. This current can be found by the (given) voltage  $U_0$  and the total resistance between the terminals  $a$  and  $b$ . So we are looking for  $R_{ab}$ .

As already described in the previous subchapters, partial circuits can also be converted into

equivalent resistors step by step. It is important to note that these partial circuits for conversion into equivalent resistors may only ever have two connections (= two nodes to the “outside world”).

Fig. 33: Step by step solution of the example



figure 33 shows the step-by-step conversion of the equivalent resistors in this example. As a result of the equivalent resistance one gets:

$$\begin{aligned}
 R_g &= R_{12345} = R_{12} || R_{345} = R_{12} || (R_3 + R_{45}) = \\
 &= (R_1 || R_2) || (R_3 + R_4 || R_5) = \frac{\frac{R_1 \cdot R_2}{R_1 + R_2} \cdot (R_3 + \frac{R_4 \cdot R_5}{R_4 + R_5})}{\frac{R_1 \cdot R_2}{R_1 + R_2} + R_3 + \frac{R_4 \cdot R_5}{R_4 + R_5}} \\
 &= \frac{R_1 \cdot R_2 \cdot (R_3 + \frac{R_4 \cdot R_5}{R_4 + R_5}) \cdot (R_4 + R_5)}{R_1 \cdot R_2 \cdot (R_3 \cdot (R_4 + R_5) + R_4 \cdot R_5) + R_3 \cdot R_4 \cdot R_5 + R_1 \cdot R_2 \cdot (R_4 + R_5)} \\
 &= \frac{R_1 \cdot R_2 \cdot (R_3 \cdot (R_4 + R_5) + R_4 \cdot R_5)}{R_1 \cdot R_2 \cdot (R_3 \cdot (R_4 + R_5) + R_4 \cdot R_5) + R_3 \cdot R_4 \cdot R_5 + R_1 \cdot R_2 \cdot (R_4 + R_5)}
 \end{aligned}$$

### Example with Δ-Y-Transformation

With the Δ-Y-transformation now also the initial example can be transformed. For more complicated circuits, the repeated Δ-Y-transformation with subsequent combining of the resistors is useful, until the resulting circuit is easily calculable with node and mesh theorem (figure 34). Here a calculation is omitted - it is recommended to calculate here with intermediate results for the transformed resistors.

Fig. 34: example circuit conversion



### Example with symmetries in the circuit

A certain special case concerns possible symmetries in circuits. If these are present, a further simplification can be made.

Fig. 35: Example with symmetries in the circuit

figure 35 shows on the left a symmetrical construction of a network of equal resistors  $R$ . For better understanding, in the middle of the same circuit additional switches and test points (TP) are installed, which indicate the voltage to ground.

The switches can be used to check whether a current flows if the respective nodes are connected. In the simulation it can be seen that this is not the case. In the symmetrical setup, these nodes are each at the same potential.

This also allows the circuit to take the form shown in figure 35 on the right. This circuit is again easy to calculate:

$$\begin{aligned} R_g &= R || R + R || R || R || R + R || R || R || R + R || R = \left\{ \frac{1}{2} \right\} \cdot R + \\ &\left\{ \frac{1}{4} \right\} \cdot R + \left\{ \frac{1}{4} \right\} \cdot R + \left\{ \frac{1}{2} \right\} \cdot R = 1.5 \cdot R \end{aligned}$$

### Exercise 2.7.1 Circuit Simplification Exercise I



**Exercise 2.7.2 Circuit Simplification Exercise II + III**



**Exercise 2.7.3 Circuit Simplification Exercise IV**



**Exercise 2.7.4 Circuit Simplification Exercise V**



**Exercise 2.7.5 Circuit Simplification Exercise V**



**Exercise 2.7.6 Circuit Simplification VI Exercise**



**Exercise 2.7.7 Simplifying Circuits (exam task, about 8% of a 60-minute exam, WS2020)**



Given is the adjoining circuit with  
 $R_1=10 \Omega$   
 $R_2=20 \Omega$   
 $R_3=5 \Omega$   
 and the switch  $S$ .

1. Determine the total resistance  $R_{\text{eq}}$  between A and B by summing the resistances with the switch  $S$  open.

Tips for solving

- How can the circuit be better represented or pulled apart?
- The switch should be replaced by an open wire in this case.

Solution

First of all, it is a good idea to reshape the circuit so that the actual structure becomes

visible.

For this purpose, the individual branches can be highlighted in color and interpreted as a “conductive rubber band”.

This results in:



Thus  $R_3$  and  $R_3$  can be combined to  $R_{33} = 2 \cdot R_3 = R_1$ , yielding a left and a right voltage divider.

Now it is visible that in the left and right voltage divider, the same potential is at the respective branch, or at the node K1 (green) and K2 (pink).

Thus, the total resistance can be calculated as  $R_{\text{eq}} = (2 \cdot R_1) \parallel (2 \cdot R_1)$ .

However, by symmetry, nodes K1 and K2 can also be short-circuited. Thus,  $R_{\text{eq}} = 2 \cdot \left( R_1 \parallel R_1 \right)$  also holds.

Final result

$$\begin{aligned} R_{\text{eq}} &= 2 \cdot \left( 10 \, \Omega \parallel 10 \, \Omega \right) = 10 \, \Omega \end{aligned}$$

2. What is the total resistance when switch  $S$  is closed?

Final result

Due to symmetry, the potentials at K1 and K2 are equal. Thus, no current flows across resistor  $R_2$  even when the switch is closed.

So the resistance remains the same.

**Exercise 2.7.8: Simplifying Circuits II (written exam task, approx 8% of a 60-minute written exam, WS2020)**

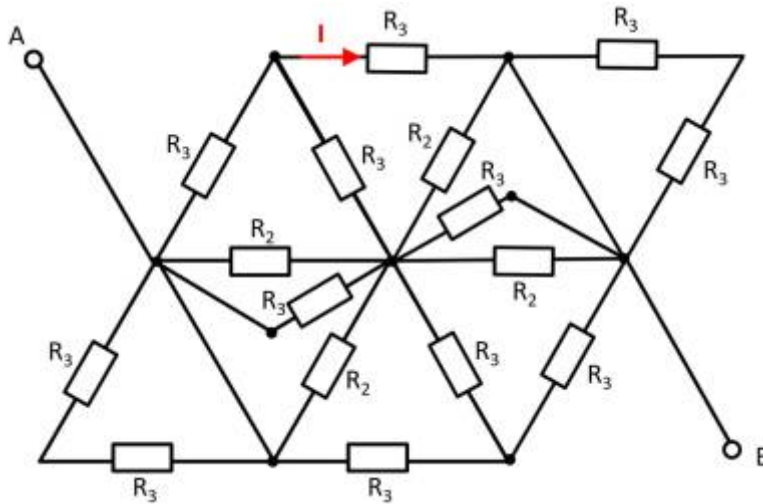

Given is the adjoining circuit with

$$R_1 = 5 \text{ } \Omega$$

$$R_2 = 10 \text{ } \Omega$$

$$R_3 = 20 \text{ } \Omega$$

1. Determine the equivalent resistance  $R_{\text{eq}}$  between A and B by summing the resistances.

Tips for solving

- How can the circuit be better represented or pulled apart?
- Switches (when used) should be replaced by an open or closed circuit.
- Does this result in equal potentials at different nodes that can be cleverly used?

Solution

First of all, it is a good idea to reshape the circuit so that the actual structure becomes visible.

For this purpose, the individual branches can be highlighted in color and interpreted as a “conductive rubber band”.

It can be seen that the two resistors  $R_3$  at the top left and bottom right are each shorted. The result is thus:





Here it helps to consider the potential of the nodes K1, K2, and K3. For K2, the resistances  $R_2 \parallel R_3 \parallel R_2$  must be combined at the top and bottom. Thus, the same resistance values at the top and bottom result. Also at the nodes K1 and K2 the same resistance values at the top and at the bottom result. With the same ratios of the resistances at K1, K2, and K3 respectively, it can be concluded that no current flows across the resistors  $R_3$  between K1 and K2 or K2 and K3. Thus, these do not contribute to the total resistance. In such a case, a short circuit or an open line can be freely chosen between the relevant nodes for the calculation. In the following, an open line is chosen. Additionally, the parallel strings can be reordered.

Fig. 36: Simulation

This results in:



$$R_{\text{eq}} = \left( \left( 2 \cdot R_2 \right) \parallel \left( 2 \cdot R_2 \right) \right) \parallel \left( \left( 2 \cdot R_3 \right) \parallel \left( 2 \cdot R_3 \right) \parallel \left( 2 \cdot R_3 \right) \right) \parallel R_2 \parallel \left( R_3 \parallel \left( 2 \cdot R_3 \right) \right) \parallel R_{\text{eq}} = R_2 \parallel \frac{R_3 \cdot 2 \cdot R_3}{R_3 + 2 \cdot R_3} \parallel R_{\text{eq}} = R_2 \parallel \frac{2}{3} \cdot R_3 \parallel R_{\text{eq}} = \frac{R_2 \cdot \frac{2}{3} \cdot R_3}{R_2 + \frac{2}{3} \cdot R_3} \parallel R_{\text{eq}} = \frac{R_2 \cdot \frac{2}{3} \cdot R_3}{\frac{3}{2} \cdot R_2 + R_3}$$

Final result

$$R_{\text{eq}} = \frac{10 \cdot 20}{\frac{3}{2} \cdot 10 + 20} = 5.7143 \Omega \rightarrow 5.7 \Omega$$

2. Now let the voltage from A to B be:  $U_{AB} = U_0 = 20 \text{ V}$ . What is the current  $I$ ?

Solution

The partial current  $I$  is obtained directly from the voltage  $U_0$ :  $I = \frac{U_0}{2 \cdot R_3}$

Final result

$$I = \frac{20 \text{ V}}{2 \cdot 20 \Omega} = 0.5 \text{ A}$$

**Exercise 2.7.9 - Variation: Simplifying Circuits II (written exam task, approx 8% of a 60-minute written exam, WS2020)**



Given is the adjoining circuit with  
 $R_1 = 10 \Omega$   
 $R_2 = 20 \Omega$   
 $R_3 = 5 \Omega$

1. Determine the equivalent resistance  $R_{\text{eq}}$  between A and B by summing the resistances.

Final result

$$R_{\text{ges}} = \frac{20 \Omega \cdot 5 \Omega}{\frac{3}{2} \cdot 20 \Omega + 5 \Omega} = 2.858 \Omega \rightarrow 2.9 \Omega$$

2. Now let the voltage from A to B be:  $U_{\text{AB}} = U_0 = 10 \text{ V}$ . What is the current  $I$ ?

Final result

$$I = \frac{10 \text{ V}}{2 \cdot 5 \Omega} = 1 \text{ A}$$

**Exercise 2.7.10 - Variation: Simplifying Circuits III (written exam task, approx 8% of a 60-minute written exam, WS2020)**

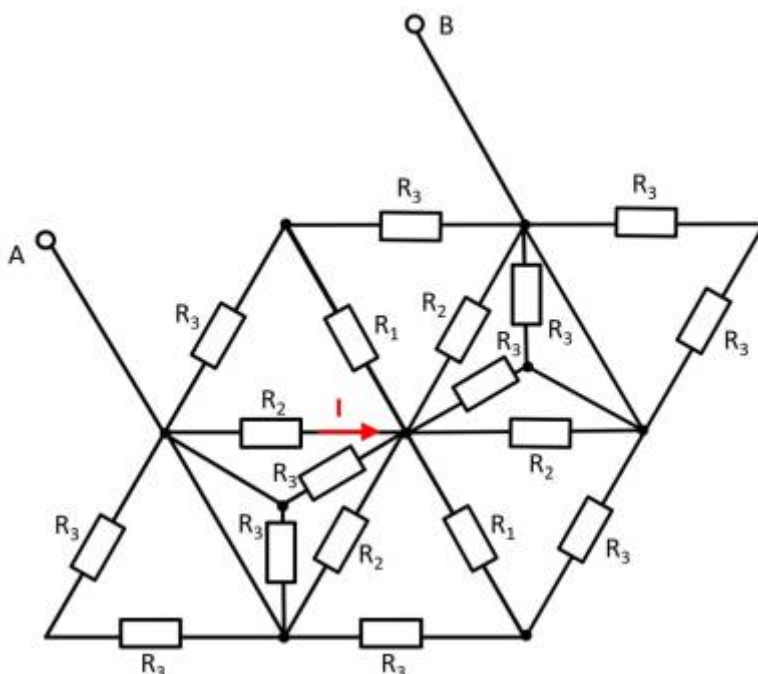

Given is the adjoining circuit with  
 $R_1 = 5 \Omega$   
 $R_2 = 20 \Omega$   
 $R_3 = 10 \Omega$

1. Determine the equivalent resistance  $R_{\text{eq}}$  between A and B by summing the resistances.

2. Now let the voltage from A to B be:  $U_{\text{AB}} = U_0 = 30 \text{ V}$ . What is the current  $I$ ?

**other Exercises**

More exercises can be found online on the pages of [HERTZ](#) (selection on the left in the menu).

From:

<https://mexle.te.hs-heilbronn.de/> - **MEXLE Wiki**

Permanent link:

[https://mexle.te.hs-heilbronn.de/electrical\\_engineering\\_1/simple\\_circuits?rev=1634110155](https://mexle.te.hs-heilbronn.de/electrical_engineering_1/simple_circuits?rev=1634110155)

Last update: **2021/10/13 09:29**

