

# 1 Preparation, Properties, and Proportions

## Student Group

First Name	Surname	Matrikel Nr.

## Table of Contents

<b>1. Preparation, Properties and Proportions</b> .....	4
<b>1.1 Physical Proportions</b> .....	4
Goals .....	4
System of Units .....	4
derived quantities, SI units and prefixes .....	5
Physical equations .....	7
Quantity equations .....	7
normalized quantity equations .....	7
Example for a quantity equation .....	7
Letters for physical quantities .....	8
Exercises .....	9
Exercise 1.1.1 Conversions I - precalculated example for the conversion of units .....	9
Exercise 1.1.2 Conversions II .....	9
Exercise 1.1.3 Conversions III .....	9
Exercise 1.1.4 Conversions IV .....	9
<b>1.2 Introduction to the structure of matter</b> .....	10
Goals .....	10
Elementary Charge .....	10
Conductivity .....	11
Conductor .....	11
Semiconductor .....	11
Isolator .....	11
Exercises .....	11
Exercise 1.2.1 Charges I .....	11
Exercise 1.2.2 Charges II .....	11
<b>1.3 Effects of electric charges and current</b> .....	12
Goals .....	12
first approximation to the el. charge .....	12
Coulomb-Force .....	12

Note!	13
<b>1.4 Charge and current</b>	13
Goal	13
qualitative View	14
Definition of current	15
Note:	15
Determination of the current direction	15
Definition of current direction (according to DIN5489)	15
Definition of electrodes (according to DIN5489)	16
Exercises	16
Exercise 1.4.1 Determining the current from the charge per time	16
Exercise 1.4.2 Electron flow	17
<b>1.5 Voltage, potential and energy</b>	17
Goals	17
Energetic Approach	17
Comparison mechanics to electrics	18
Mechanical System	19
Electrical System	19
Note:	20
Definition of voltage	20
voltage between two points	20
Definition of the conventional direction of the voltage (according to DIN5489)	20
Exercises	20
Exercise 1.5.1 Direction of the voltage	20
<b>1.6 Resistance and conductance</b>	21
Goals	21
Linearity of resistors	22
Linear resistors	22
Non-linear resistors	22
Resistance as a material property	22
Note:	23
Temperature dependence of resistors	24
Note:	25
Outlook	26
Types of temperature dependent resistors	26
NTC thermistor	26
PTC termistor	26
Resistor packages	27
Exercises	28
Exercise 1.6.1 Pre-calculated example of resistivity	28
Exercise 1.6.2 Resistance of a pencil stroke	28
Exercise 1.6.3 Resistance of a cylindrical coil	28
Exercise 1.6.4 Resistance of a supply line	28
Exercise 1.6.5 Strain gauges	29
Exercise 1.6.6: Temperature-dependent resistance of a winding (written test, approx. 6 % of a 60-minute written test, WS2020)	29
<b>1.7 Power and efficiency</b>	29
Goal	30
Determining the electrical power in a DC circuit	30
Nominal quantities of ohmic loads	31
Efficiency	31

---

Exercises .....	32
Exercise 1.7.1 Pre-calculated example of electrical power and energy .....	33
Exercise 1.7.2 Power .....	33
Exercise 1.7.3 Power loss and efficiency I .....	33
Exercise 1.7.4 Power loss and efficiency II .....	34
Exercise 1.7.5 PPTC .....	34
<b>Further reading</b> .....	35

# 1. Preparation, Properties and Proportions

## 1.1 Physical Proportions

### Goals

After this lesson you should:

1. know the basic physical quantities and the associated SI units.
2. know the most important prefixes. Be able to assign a power of ten to the respective abbreviation (G, M, k, d, c, m,  $\mu$ , n).
3. be able to insert given numerical values and units into an existing quantity equation. From this you should be able to calculate the correct result using a calculator.
4. be able to assign the Greek letters.
5. always calculate with numerical value and unit.
6. know that a related quantity equation is dimensionless!

A nice 10 minute intro into some of the main topics of this chapter



### System of Units

Short presentation of the SI units



Base quantity	Name	Unit	Definition
Time	Second	s	Oscillation of $^{133}\text{Cs}$ -Atom
Length	Meter	m	by s und speed of light
el. Current	Ampere	A	by s and elementary charge
Mass	Kilogram	kg	still by kg prototype
Temperature	Kelvin	K	by triple point of water
amount of substance	Mol	mol	via number of $^{12}\text{C}$ nuklides
luminous intensity	Candela	cd	via given radiant intensity

Tab. 1: SI-System

- For practical applications of physical laws of nature, **physical quantities** are put into mathematical relationships.
- There are basic quantities based on the SI system of units (French for *Système International d'Unités*), see below.
- In order to determine the basic quantities quantitatively (quantum = Latin for “how big”), **physical units** are defined, e.g. *metre* for length.
- In electrical engineering, the first three basic quantities (cf. [table 1](#)) are particularly important. Mass is important for the representation of energy and power.
- Each physical quantity is indicated by a product of **numerical value** and **unit**: \e.g.  $I = 2 \text{ A}$ 
  - This is the short form of  $I = 2 \cdot 1 \text{ A}$
  - $I$  is the physical quantity, here: electric current strength
  - $\{I\} = 2$  is the numerical value
  - $[I] = 1 \text{ A}$  is the (measurement) unit, here: Ampere

## derived quantities, SI units and prefixes

Importance of orders of magnitude in engineering (when the given examples in the video are unclear: we will get into this.)



prefix	prefix symbol	meaning
Yotta	Y	$10^{24}$
Zetta	Z	$10^{21}$
Exa	E	$10^{18}$
Peta	P	$10^{15}$
Tera	T	$10^{12}$
Giga	G	$10^9$
Mega	M	$10^6$
Kilo	k	$10^3$
Hecto	h	$10^2$
Deka	de	$10^1$

Tab. 2: Prefixes I

prefix	prefix symbol	meaning
Deci	d	$10^{-1}$
Centi	c	$10^{-2}$
Milli	m	$10^{-3}$
Micro	u, $\mu$	$10^{-6}$
Nano	n	$10^{-9}$
Piko	p	$10^{-12}$
Femto	f	$10^{-15}$
Atto	a	$10^{-18}$
Zeppto	z	$10^{-21}$
Yocto	y	$10^{-24}$

Tab. 2: Prefixes II

- Besides the basic quantities, there are also quantities derived from them, e.g.  $\frac{m}{s}$ .
- SI units should be preferred for calculations. These can be derived from the basic quantities **without a numerical factor**.
  - The pressure unit bar (bar) is an SI unit.
  - BUT: The obsolete pressure unit atmospheric ( $=1.013 \text{ bar}$ ) is **not** an SI unit.
- To prevent the numerical value from becoming too large or too small, it is possible to replace a decimal factor with a prefix. These are listed in [table 2](#).

## Physical equations

- Physical equations allow a connection of physical quantities.
- There are two types of physical equations to distinguish (at least in German):
  - Quantity equations (Größengleichungen)
  - Normalized quantity equations (also called related quantity equations, normierte Größengleichungen)

### Quantity equations

The vast majority of physical equations result in a physical unit that is not equal to 1.

Example: Force  $F = m \cdot a$  with  $[F] = \text{kg} \cdot \frac{\text{m}}{\text{s}^2}$

- A unit check should always be performed for quantity equations
- Quantity equations should generally be preferred

### normalized quantity equations

In normalized quantity equations, the measured value or calculated value of a quantity equation is divided by a reference value. This results in a dimensionless quantity relative to the reference value.

Example: Efficiency  $\eta = \frac{P_{\text{out}}}{P_{\text{in}}}$

As reference value are often used:

- Nominal values (maximum permissible value in continuous operation) or
- Maximum values (maximum value achievable in the short term)

For normalized quantity equations, the units should **always** cancel out.

### Example for a quantity equation

Let a body with the mass  $m = 100\text{kg}$  be given. The body is lifted by the height  $s=2\text{m}$ .  
What is the value of the needed work?

physical equation:

$$\text{Work} = \text{Force} \cdot \text{displacement}$$

$$W = F \cdot s \quad \text{where } F = m \cdot g$$

$$W = m \cdot g \cdot s \quad \text{where } m = 100 \text{ kg}, s = 2 \text{ m} \text{ and}$$

$$g = 9.81 \frac{\text{m}}{\text{s}^2}$$

$$W = 100 \text{ kg} \cdot 9.81 \frac{\text{m}}{\text{s}^2} \cdot 2 \text{ m}$$

$$W = 100 \cdot 9.81 \cdot 2 \text{ kg} \cdot \frac{\text{m}}{\text{s}^2} \cdot \text{m}$$

$$W = 1962 \text{ kg} \cdot \frac{\text{m}}{\text{s}^2} \cdot \text{m}$$

$$W = 1962 \text{ Nm} = 1962 \text{ J}$$

## Letters for physical quantities

Uppercase letters	Lowercase letters	Name
$A$	$\alpha$	Alpha
$B$	$\beta$	Beta
$\Gamma$	$\gamma$	Gamma
$\Delta$	$\delta$	Delta
$E$	$\epsilon$ , $\varepsilon$	Epsilon
$Z$	$\zeta$	Zeta
$H$	$\eta$	Eta
$\Theta$	$\theta$ , $\vartheta$	Theta
$I$	$\iota$	Iota
$K$	$\kappa$	Kappa
$\Lambda$	$\lambda$	Lambda
$M$	$\mu$	Mu
$N$	$\nu$	Nu
$\Xi$	$\xi$	Xi
$O$	$\omicron$	Omicron
$\Pi$	$\pi$	Pi
$R$	$\rho$ , $\varrho$	Rho
$\Sigma$	$\sigma$	Sigma
$T$	$\tau$	Tau
$\Upsilon$	$\upsilon$	Upsilon
$\Phi$	$\phi$ , $\varphi$	Phi
$X$	$\chi$	Chi
$\Psi$	$\psi$	Psi
$\Omega$	$\omega$	Omega

Tab. 4: greek letters

In physics and electrical engineering, the letters for physical quantities are often close to the English term.

Thus explains  $C$  for **C**apacity,  $Q$  for **Q**uantity and  $\varepsilon_0$  for the **E**lectrical Field Constant. But, maybe you already know that  $C$  is used for the thermal capacity as well as for the electrical capacity. The Latin alphabet has not enough letters to avoid conflicts for the scope of physics. For this reason, Greek letters are used for various physical quantities (see [table 4](#)).

Especially in electrical engineering, **upper/lower case letters** are used to distinguish between

- a constant (time-independent) quantity,  
e.g. the period  $T$
- or a time-dependent quantity,  
e.g. the instantaneous voltage  $u(t)$

The relevant Greek letters for electrical engineering are described in the following video.

## Exercises

### Exercise 1.1.1 Conversions I - precalculated example for the conversion of units



### Exercise 1.1.2 Conversions II

Convert the following values step by step:

- A vehicle speed of 80 km/h in m/s
- An energy of 60 joules in kWh (1 joule = 1 watt\*second)
- The number of electrolytically deposited single positively charged copper ions of 1.2 coulombs (a copper ion has the charge of about  $1.6 \cdot 10^{-19}$  C)
- Absorbed energy of a small IoT consumer, which consumes  $1 \mu\text{W}$  uniformly in 10 days

### Exercise 1.1.3 Conversions III

Convert the following values step by step: How many minutes could an ideal battery with 10 kWh operate a consumer with 3W?

### Exercise 1.1.4 Conversions IV

Convert the following values step by step: How much energy does an average household consume per day when consuming an average power of 500 W? How many chocolate bars (2000 kJ each) does this correspond to?

## 1.2 Introduction to the structure of matter

### Goals

After this lesson you should:

1. know the size of the elementary charge

### Elementary Charge

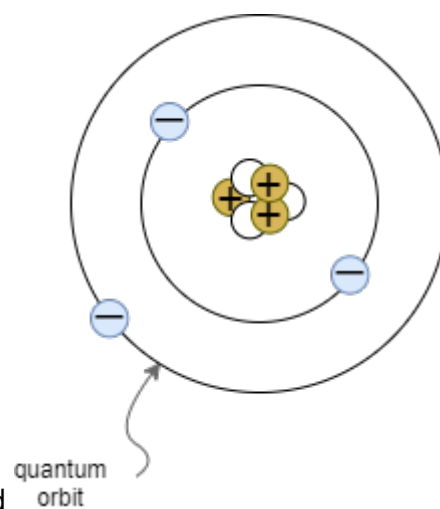
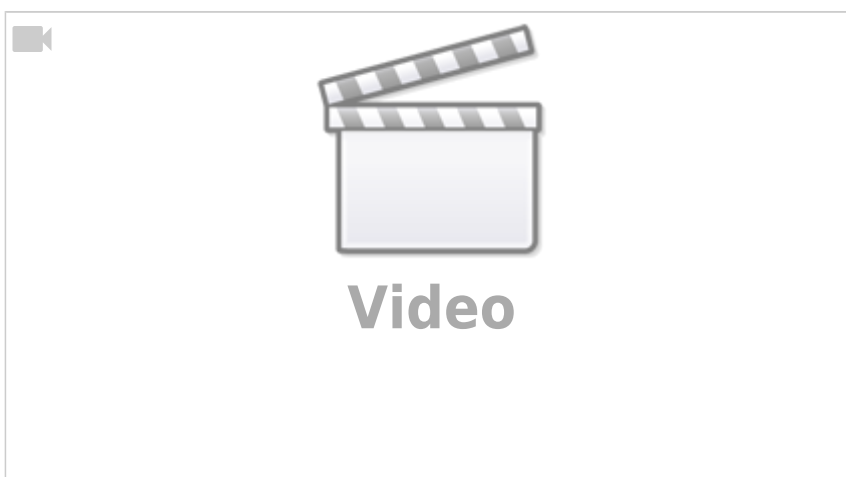

Fig. 9: Atomic model according to Bohr / Sommerfeld

### Charge in Matter



- Explanation of the charge on the basis of the atomic models according to Bohr and Sommerfeld (see [figure 9](#))
- Atoms consist of
  - Atomic nucleus (with protons and neutrons)
  - Electron shell
- Electrons are carriers of the elementary charge  $|e|$

- elementary charge  $|e| = 1.6022 \cdot 10^{-19} \text{ C}$
- Proton is the antagonist, i.e. has opposite charge
- Sign is arbitrarily chosen:
  - Electron charge:  $-e$
  - proton charge:  $+e$
- all charges on/in bodies can only occur as integer multiples of the elementary charge.
- Due to the small numerical value of  $e$ , the charge is considered as a continuum when viewed macroscopically.

## Conductivity

<p><b>Conductor</b></p> <p>Charge carriers are freely movable in the conductor.</p> <p>Examples:</p> <ul style="list-style-type: none"> <li>• Metals</li> <li>• Plasma</li> </ul>	<p><b>Semiconductor</b></p> <p>In semiconductors, charge carriers can be generated by heat and light irradiation. Often a small movement of electrons is already possible by room temperature.</p> <p>Examples:</p> <ul style="list-style-type: none"> <li>• Silicon</li> <li>• diamond</li> </ul>	<p><b>Isolator</b></p> <p>In the insulator, charge carriers are firmly bound to the atomic shells.</p> <p>Examples:</p> <ul style="list-style-type: none"> <li>• many plastics and salts</li> </ul>	<p><b>Exercises</b></p> <p><b>Exercise 1.2.1 Charges I</b></p> <p>How many electrons make up the charge of one coulomb?</p> <p><b>Exercise 1.2.2 Charges II</b></p> <p>A balloon has a charge of <math>Q = 7 \text{ nC}</math> on its surface. How many additional electrons are on the balloon?</p>
---	--	---	--

## 1.3 Effects of electric charges and current

### Goals

After this lesson you should:

1. Know that forces act between charges.
2. Know and be able to apply Coulomb's law.

- What effects of electric charges and current do you know?

### first approximation to the el. charge

Fig. 10: Experiment 1 with two suspended charges

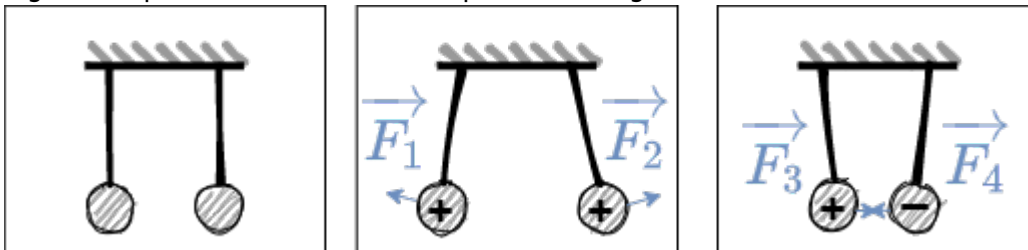

- first attempt (see [figure 10](#)):
  - Two charges ( $Q_1$  and  $Q_2$ ) are suspended at a distance of  $r$ .
  - Charges are generated by high voltage source and transferred to the two test specimens
- Result
  - samples with same charges  $\rightarrow$  Repulsion
  - samples with charges of different sign  $\rightarrow$  attraction
- Findings
  - Forces cannot be explained mechanically
  - There seem to be two different types of charges.  $\rightarrow$  positive (+) and negative (-) charge

### Coulomb-Force

Setup for own experiments

Take a charge ( $+1\text{nC}$ ) and position it. Measure the field across a sample charge (a sensor).

Experiment on Coulomb's law and some calculated exercises

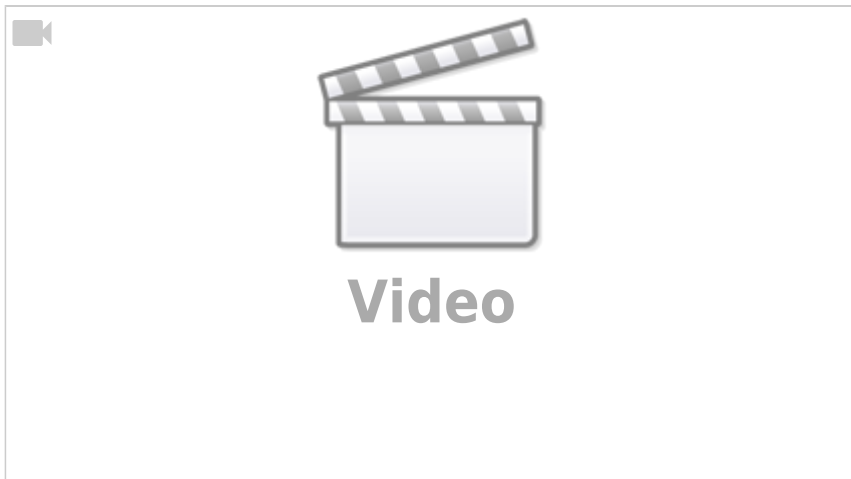

- Qualitative investigation by means of a second experiment
  - two charges ( $Q_1$  and  $Q_2$ ) at distance  $r$
  - additional measurement of the force  $F_C$  (e.g. via spring balance)
- Experiment results:
  - Force increases linearly with larger charge  $Q_1$  or  $Q_2$ .  
 $F_C \sim Q_1$  and  $F_C \sim Q_2$
  - Force falls quadratically with greater distance  $r$   
 $F_C \sim \frac{1}{r^2}$
  - with a proportionality factor  $a$ :  
 $F_C = a \cdot \frac{Q_1 \cdot Q_2}{r^2}$
- Proportionality factor  $a$
- The proportionality factor  $a$  is defined in such a way that simpler relations arise in electrostatics.
  - $a$  thus becomes:
  - $a = \frac{1}{4\pi \cdot \epsilon_0}$
  - $\epsilon_0$  is the **Coulomb constant** (also called electric field constant). In a vacuum,  
 $\epsilon_0 = \epsilon_0$ .
- The formula is similar to that of the gravitational force:  $F_G = \gamma \cdot \frac{m_1 \cdot m_2}{r^2}$

### Note!

The Coulomb force (in a vacuum) can be calculated via.

$$\boxed{F_C = \frac{1}{4\pi \cdot \epsilon_0} \cdot \frac{Q_1 \cdot Q_2}{r^2}}$$

where  $\epsilon_0 = 8.85 \cdot 10^{-12} \cdot \frac{C^2}{m^2 \cdot N} = 8.85 \cdot 10^{-12} \cdot \frac{As}{Vm}$

## 1.4 Charge and current

### Goal

Goals After this lesson you should:

- Be able to distinguish the direction of conventional current and the flow of electrons.

- Be able to determine the cathode and anode of components
- Be able to apply the definition of current

## What is Electric Charge and How Electricity Works



- From the previous experiments it is clear that there are two types of charge. In matter these are:
  - (+)  $\rightarrow$  excess of positive charges.
  - (-)  $\rightarrow$  excess of negative charges
- further experiment:
  - (+) and (-) are connected by a conductor
  - $\rightarrow$  electrons move from (-)-pole to (+)-pole
  - $\rightarrow$  electric current

## qualitative View

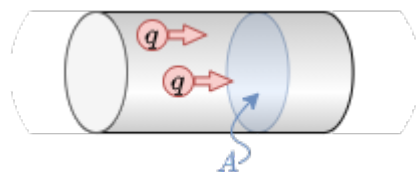

Fig. 11: Part of a Conductor

- In the thought experiment, let the following be given (see [figure 11](#)):
  - the above-mentioned conductor with a cross-section  $A$  perpendicular to the conductor
  - the quantity of charges  $\Delta Q = n \cdot e \cdot \Delta t$ , which in a certain period of time  $\Delta t$ , pass through the area  $A$
- In the case of a uniform charge transport over a longer period of time, i.e. direct current (DC), the following applies:
  - The amount of charges per time flowing through the surface is constant:
 
$$\frac{\Delta Q}{\Delta t} = \text{const.} = I$$
  - $I$  denotes the strength of the direct current.
  - The unit of  $I$  is the SI unit ampere:  $1 \text{ A} = \frac{1 \text{ C}}{1 \text{ s}}$ . Thus, for the unit coulomb applies:  $1 \text{ C} = 1 \text{ A} \cdot \text{s}$

### Definition of current

The current of  $1\text{ A}$  flows when an amount of charge of  $1\text{ C}$  is transported in  $1\text{ s}$  through the cross section of the conductor.

Before 2019: The current of  $1\text{ A}$  flows when two parallel conductors, each  $1\text{ m}$  long and  $1\text{ m}$  apart, exert a force of  $F_C = 0.2 \cdot 10^{-6}\text{ N}$  on each other.

### Note:

An electric current is the directed movement of free electric charge carriers.

## Determination of the current direction

Fig. 12: Part of a conductor with different charged charges



Charge transport can take place through (figure 12):

- negative charge carriers  $\Delta Q_n$  (e.g. electrons in a metallic conductor).
- positive charge carriers  $\Delta Q_p$  (e.g. certain semiconductor materials or in electrochemical cells)
- positive and negative charge carriers (e.g. certain semiconductor materials, plasma)

The total transported charge is  $\Delta Q = \Delta Q_p - \Delta Q_n = n_p \cdot e - n_n \cdot (-e)$

$\rightarrow$  The direction of current must be determined independently of the direction of motion of the electric charge carriers.

### Definition of current direction (according to DIN5489)

The current in a conductor from a cross-sectional area  $A_1$  to a cross-sectional area  $A_2$  is calculated positively, when:

- positive charge carriers move from  $A_1$  to  $A_2$ , resp
- negative charge carriers move from  $A_2$  to  $A_1$ .

The direction of the conventional current (or technical direction of current) is the direction of the positive current, i.e. the positive charge carriers.

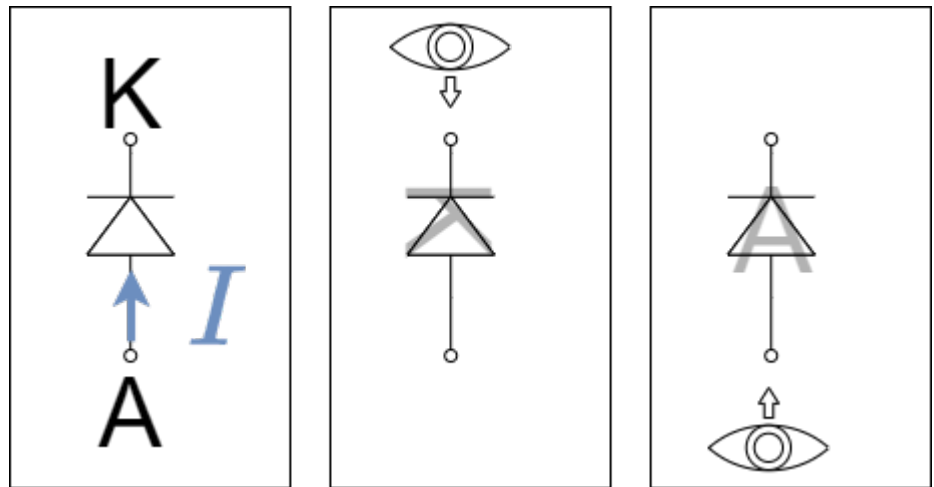

Fig. 13: Electrodes on the diode

### Definition of electrodes (according to DIN5489)

An electrode is a connection (or pin) of an electrical component. As a rule, electrodes are characterized by the fact that a change of material takes place (e.g. metal->semiconductor, metal->liquid)

- Anode: Electrode at which the current enters the component.
- Cathode: Electrode at which the current exits the component.

As a mnemonic you can remember the structure, shape and electrodes of the diode (see [figure 13](#)).

## Exercises

### Exercise 1.4.1 Determining the current from the charge per time



Fig. ##: Time course of the charge

Let the charge gain per time on an object be given.

- Determine from the diagram [figure ##](#) and plot them on the diagram.
- How could you proceed if the amount of charge on the object changes non-linearly?

### Exercise 1.4.2 Electron flow

How many electrons pass through a control cross section of a metallic conductor when the current of  $40\text{mA}$  flows for  $4.5\text{s}$ ?

## 1.5 Voltage, potential and energy

### Goals

After this lesson you should be able to:

1. to determine the energy gain of a charge when overcoming a voltage difference.

### Energetic Approach

Voltage vs Power vs Energy



Fig. 16: Symbolic image of an electric circuit

Given is an electrical conductor (“consumer”) at a battery (see [figure 16](#))

- $\rightarrow$  Current flows
- Similar to the transport of a mass in the gravitational field, energy is needed to transport the charge in the “voltage field”
- We will look at the specific electric field in the next semester
- A point charge  $q$  is moved from electrode ① to electrode ②.  
The charge resembles a moving point of mass in the gravitational field.
- $\rightarrow$  there is a turnover of energy.
- The energy turnover is proportional to the amount of charge  $q$  transported.
- In many cases, the “energetic path” from ① to ② has to be characterized in charge-independent terms:  
 $\boxed{\frac{W_{1,2}}{q} = U_{1,2}}$
- $V$  for Voltage is often used to denote the unit AND the quantity (in German  $U$  is used for the quantity):
- e.g.
  - $V_{CC} = 5V$  : Voltage supply of an IC (Voltage Common Collector),
  - $V_{S+} = 15V$  : Voltage supply of an operational amplifier (Voltage Supply plus).

## Comparison mechanics to electrics

Fig. 17: Mechanical potential

Fig. 18: Electrical Potential

Ele  
ctri  
c -  
Hyd  
raul  
ic  
Ana

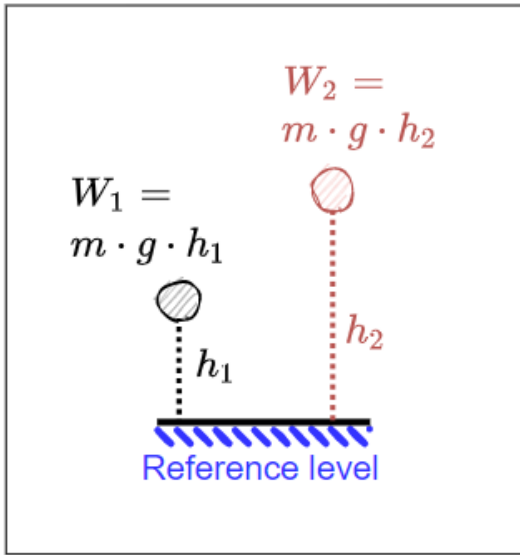

**Mechanical System**

**Potential Energy**

Potential energy is always related to a reference level (reference height). The energy required to move  $m$  from  $h_1$  to  $h_2$  is independent of the reference level.

$$\Delta W = W_1 - W_2 = m \cdot g \cdot (h_1 - h_2)$$



**Electrical System**

**Potential**

The potential  $\varphi$  is always specified relative to a reference point.

Common used are:

- Earth potential (ground, earth, ground).
- infinitely distant point

To shift the charge, the potential difference must be overcome. The potential difference is independent of the reference potential.  $\Delta W_{1,2} = W_1 - W_2 = Q \cdot \varphi_1 - Q \cdot \varphi_2 = Q \cdot (\varphi_1 - \varphi_2)$

log  
y:  
Cha  
rge,  
Volt  
age  
,  
and  
Cur  
rent



V  
i  
d  
e  
o



It follows that:

$$\boxed{\{\Delta W_{1,2} \over \{Q\}} = \varphi_1 - \varphi_2 = U_{1,2}\}}$$

### Note:

- Voltage is always a potential difference.
- The unit of voltage is Volt:  $1 \text{ V}$

### Definition of voltage

A voltage of  $1 \text{ V}$  is present between two points if a charge of  $1 \text{ C}$  undergoes an energy change of  $1 \text{ J} = 1 \text{ Nm}$  between these two points.

From  $W = U \cdot Q$  also the unit results:  $1 \text{ Nm} = 1 \text{ V} \cdot \text{As} \rightarrow 1 \text{ V} = 1 \frac{\text{Nm}}{\text{As}}$

## voltage between two points

For the voltage between two points, using what we know so far, we get the following definition:

$$U_{12} = \varphi_1 - \varphi_2 = -U_{21} = -(\varphi_2 - \varphi_1)$$

Thus, the order of the indices must always be observed in the following.

### Definition of the conventional direction of the voltage (according to DIN5489)

The voltage of  $U_{12}$  along a path from point ① to ② becomes positive when the potential in ① is greater than the potential in ②.

## Exercises

### Exercise 1.5.1 Direction of the voltage



Fig. 19: Example of conventional voltage specification

Explain whether the voltages  $U_{\text{Batt}}$ ,  $U_{12}$  and  $U_{21}$  in [figure 19](#) are positive or negative according to the voltage definition.

## 1.6 Resistance and conductance

### Goals

After this lesson you should:

- Know and be able to apply Ohm's law.
- Be able to calculate resistance from (specific) resistivity.
- Be able to determine the conductance from the resistance or the specific conductivity.
- know which cases of temperature dependence are distinguished and how they are named.
- be able to calculate the resistance at different temperatures.
- know that there are different types of construction and that the physical value of the resistance does not depend on the geometric value.

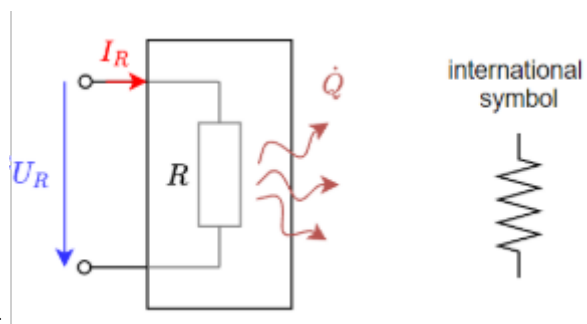

Fig. 20: resistor as two-terminal component

Current flow generally requires energy input. This energy is extracted from the electric circuit and is usually converted into heat. The reason for this is the resistance of the conductor.

A resistor is an electrical component with two connections (or terminals). Components with two terminals are called two-terminal network or one-port network ([figure 20](#)). In later in the semester, four-terminal network will also be added.

In general, the cause-and-effect relationship is such that an applied voltage across the resistor produces the current flow. However, the reverse relationship also applies: as soon as an electric current flows across a resistor, a voltage drop is produced across the resistor. In electrical engineering, circuit diagrams use idealized components in a [Lumped-element model](#). The resistance of the wires is either neglected - if it is very small compared to all other resistance values - or drawn as a separate resistor.

## Linearity of resistors

### Linear resistors

Fig. 21: Linear resistors in the U-I diagram



- For linear resistors, the resistance value is  $R = \frac{U_R}{I_R} = \text{const.}$  and thus independent of  $U_R$ .
- **Ohm's law** results:  $R = \frac{U_R}{I_R}$  with unit  $R = \frac{[U_R]}{[I_R]} = 1 \frac{[V]}{[A]} = 1 \Omega$
- In figure 21 the value  $R$  can be read from the course of the straight line  $R = \frac{\Delta U_R}{\Delta I_R}$
- The reciprocal value (inverse) of the resistance is called the conductance:  $G = \frac{1}{R}$  with unit  $1 \text{ S}$  (Siemens). This value can be seen as a slope in the  $U$ - $I$  diagram.

### Non-linear resistors

Fig. 23: Non-linear resistors in the U-I diagram



- The point in the  $U$ - $I$  diagram in which a system rests is called the operating point. In the figure 23 an operating point is marked with a circle in the left diagram.
- For nonlinear resistors, the resistance value is  $R = \frac{U_R}{I_R(U_R)} = f(U_R)$ . This resistance value depends on the operating point.
- Often small changes around the operating point are of interest (e.g. for small disturbances of load machines). For this purpose, the differential resistance  $r$  (also dynamic resistance) is determined:  $r = \frac{dU_R}{dI_R} \approx \frac{\Delta U_R}{\Delta I_R}$  with unit  $[R] = 1 \Omega$ .
- As with the resistor  $R$ , the reciprocal of the differential resistance  $r$  is the differential conductance  $g$ .
- In figure 23 the differential conductance  $g$  can be read from the slope of the straight line at each point  $g = \frac{dI_R}{dU_R}$

## Resistance as a material property

Clear explanation of resistivity

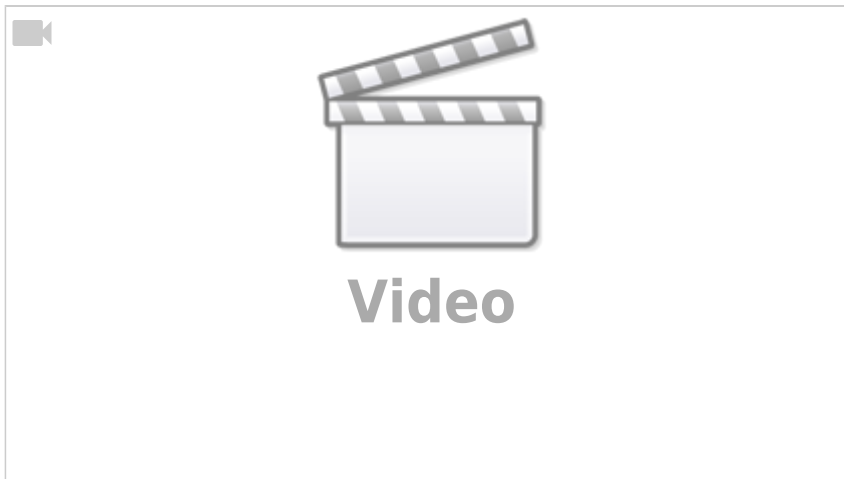

The value of the resistance can also be derived from the geometry of the resistor. For this purpose, an experiment can be carried out with resistors of different shapes. Thereby it can be stated:

- the resistance  $R$  increases proportionally with the distance  $l$  the current has to travel:  $R \sim l$
- the resistance  $R$  decreases inversely proportional with the cross-sectional area  $A$  through which the current passes:  $R \sim \frac{1}{A}$
- the resistance  $R$  depends on the material (table 5)
- thus one obtains:  
 $R \sim \frac{l}{A}$

Material	$\rho$ in $\frac{\Omega \cdot \text{mm}^2}{\text{m}}$
Silver	$1.59 \cdot 10^{-2}$
Copper	$1.79 \cdot 10^{-2}$
Aluminium	$2.78 \cdot 10^{-2}$
Gold	$2.2 \cdot 10^{-2}$
Lead	$2.1 \cdot 10^{-1}$
Graphite	$8 \cdot 10^0$
Battery acid (laed-acid battery)	$1.5 \cdot 10^4$
Blood	$1.6 \cdot 10^6$
(tap) water	$2 \cdot 10^7$
Paper	$1 \cdot 10^{15} \dots 1 \cdot 10^{17}$

Tab. 5: Specific resistivity for different materials

### Note:

The resistance can be calculated by

$$R = \rho \cdot \frac{l}{A}$$

- $\rho$  is the material dependent resistivity with the unit:  
 $[\rho] = \frac{[R] \cdot [A]}{[l]} = 1 \frac{\Omega \cdot \text{m}^{\text{not } 2}}{\text{not } \text{m}} = 1 \frac{\Omega \cdot \text{m}}{\text{m}}$
- Often, instead of  $1 \frac{\Omega \cdot \text{m}}{\text{m}}$ , the unit  $1 \frac{\Omega \cdot \text{mm}^2}{\text{m}}$  is used. It holds that  $1 \frac{\Omega \cdot \text{mm}^2}{\text{m}} = 10^{-6} \frac{\Omega \cdot \text{m}}{\text{m}}$

- There exists also a specific conductance  $\kappa$ , given by the conductance  $G$ :  $G = \kappa \cdot \frac{A}{l}$ 
  - The specific conductance  $\kappa$  is the reciprocal of the specific resistance  $\rho$ :  $\kappa = \frac{1}{\rho}$

## Temperature dependence of resistors

Explanation of the temperature dependence of resistors



Fig. 24: Circuit for measuring the effect of temperature on a resistor

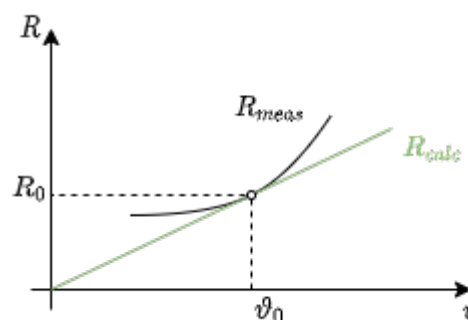
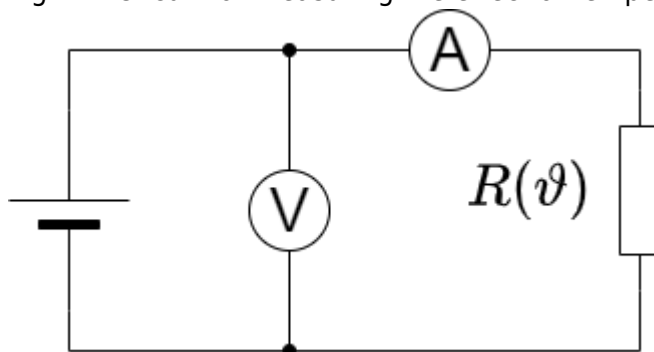

Fig. 25: Influence of temperature on resistance

The resistance value is - apart from the influences of geometry and material mentioned so far - also influenced by other effects. These are e.g.:

- Heat (thermoresistive effect, e.g. in the resistance thermometer)
- Light (photoresistive effect, e.g. in the component photo resistor)
- Magnetic field (magnetoresistive effect, e.g. in hard disks)

- Pressure (piezoresistive effect e.g. tire pressure sensor)
- Chemical environment (chemoresistive effect e.g. chemical analysis of breathing air)

In order to summarize these influences in a formula, the mathematical tool of [Taylor series](#) is often used. This will be shown here practically for the thermoresistive effect. The thermoresistive effect, or the temperature dependence of the resistivity, is one of the most common (interference) influences in components.

The starting point for this is again an experiment. The ohmic resistance is to be determined as a function of temperature. For this purpose, the resistance is measured by means of a voltage source, a voltmeter (voltage measuring device) and an ammeter (current measuring device) and the temperature is changed ([figure 24](#)).

The result is a curve of the resistance  $R$  versus the temperature  $\vartheta$  as shown in [figure 25](#). This is approximated in a first approximation by a linear progression around an operating point. This results in:

$$R(\vartheta) = R_0 + c \cdot (\vartheta - \vartheta_0)$$

- The constant is replaced by  $c = R_0 \cdot \alpha$
- $\alpha$  here is the linear temperature coefficient with unit:  $[\alpha] = \frac{1}{\vartheta} = \frac{1}{K}$
- Besides the linear term, it is also possible to increase the accuracy of the calculation of  $R(\vartheta)$  with higher exponents of the temperature influence. This approach will be discussed in more detail in the mathematics section below.
- These temperature coefficients are described with Greek letters:  $\alpha$ ,  $\beta$ ,  $\gamma$ , ...

### Note:

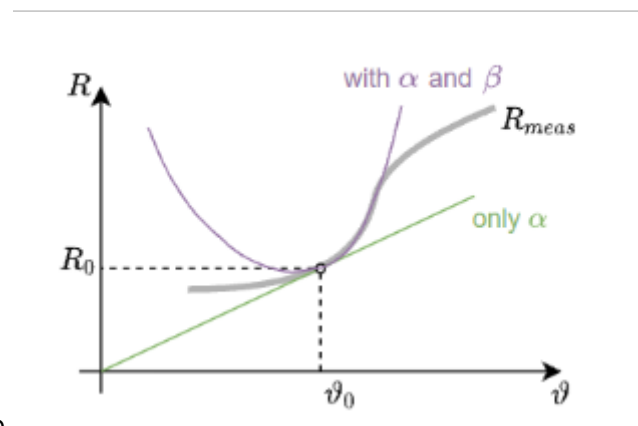

Fig. 26: Influence of temperature on resistance

The temperature dependence of the resistance is described by the following equation:

$$\boxed{R(\vartheta) = R_0 (1 + \alpha \cdot (\vartheta - \vartheta_0) + \beta \cdot (\vartheta - \vartheta_0)^2 + \gamma \cdot (\vartheta - \vartheta_0)^3 + \dots)}$$

Where:

- $\alpha$  the (linear) temperature coefficient with unit:  $[\alpha] = \frac{1}{K}$
- $\beta$  the (quadratic) temperature coefficient with unit:  $[\beta] = \frac{1}{K^2}$
- $\gamma$  the temperature coefficient with unit:  $[\gamma] = \frac{1}{K^3}$
- $\vartheta_0$  is the given reference temperature, usually  $0^\circ\text{C}$  or  $25^\circ\text{C}$ .

The further the temperature range deviates from the reference temperature, the more temperature coefficients are required to reproduce the actual curve (figure 26).

### Outlook

In addition to the specification of the parameters  $\alpha, \beta, \dots$ , the specification of  $R_{25}$  and  $B_{25}$  can occasionally be found. This is a different variant of approximation, which refers to the temperature of  $25^\circ\text{C}$ . It is based on the [Arrhenius equation](#), which links reaction kinetics to temperature in chemistry. For the temperature dependence of the resistance, the Arrhenius equation links the inhibition of carrier motion by lattice vibrations to the temperature  $R(T) \sim e^{\frac{B}{T}}$ .

A series expansion can again be applied:  $R(T) \sim e^{A + \frac{B}{T} + \frac{C}{T^2} + \dots}$ .

However, often only  $B$  is given.

By taking the ratio of any temperature  $T$  and  $T_{25} = 298.15 \text{ K}$  ( $\hat{=} 25^\circ\text{C}$ ) we get:  $\frac{R(T)}{R_{25}} = \frac{\exp\left(\frac{B}{T}\right)}{\exp\left(\frac{B}{298.15 \text{ K}}\right)}$  with  $R_{25} = R(T_{25})$

This allows the final formula to be determined:  $R(T) = R_{25} \cdot \exp\left(\frac{B_{25}}{T} - \frac{B_{25}}{298.15 \text{ K}}\right)$

## Types of temperature dependent resistors

Besides the temperature dependence as a disturbing influence, there are also components which have been deliberately bred for a specific temperature influence. These are called thermistors (a portmanteau of thermally sensitive resistor). Thermistors are basically divided into hot conductors and cold conductors.

A special form of thermistors are materials that have been explicitly optimized for minimum temperature dependence (e.g. Constantan or Isaohm).

### NTC thermistor

Fig. 27: NTC thermistor in the U-I-diagram

### PTC thermistor

Fig. 28: PTC thermistor in the U-I diagram

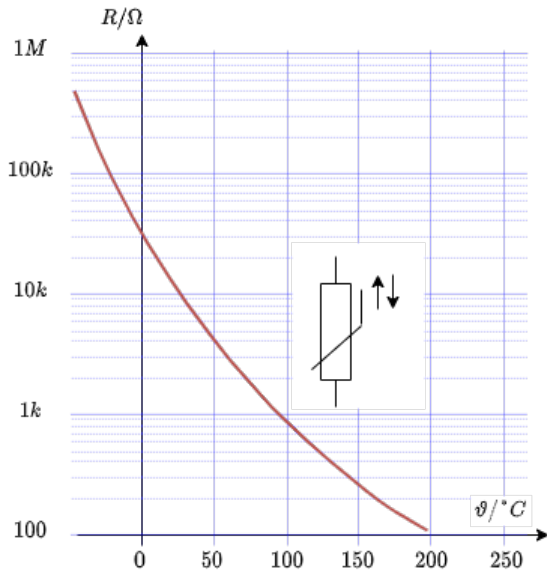

- As the name suggests, the NTC has a negative temperature coefficient. This leads to lower resistance at higher temperatures.
- Such a NTC thermistor is also called Heißeleiter in German (“hot conductor”).
- Examples are semiconductors
- Applications are inrush current limiters and temperature sensors. For the desired operating point, a strongly non-linear curve is selected there (e.g. fever thermometer).

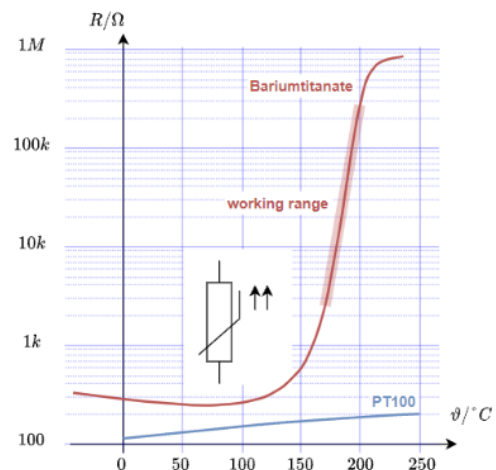

- As the name suggests, the PTC has a positive temperature coefficient. This leads to lower resistance at lower temperatures.
- Such a PTC thermistor is also called Kaltleiter in German (“cold conductor”).
- Examples are doped semiconductors or metals.
- Applications are temperature sensors. For this purpose they often offer a wide temperature range and good linearity (e.g. PT100 in the range of  $-100^{\circ}\text{C}$  to  $200^{\circ}\text{C}$ ).
- [Interactive example](#) for PTC thermistors

## Resistor packages

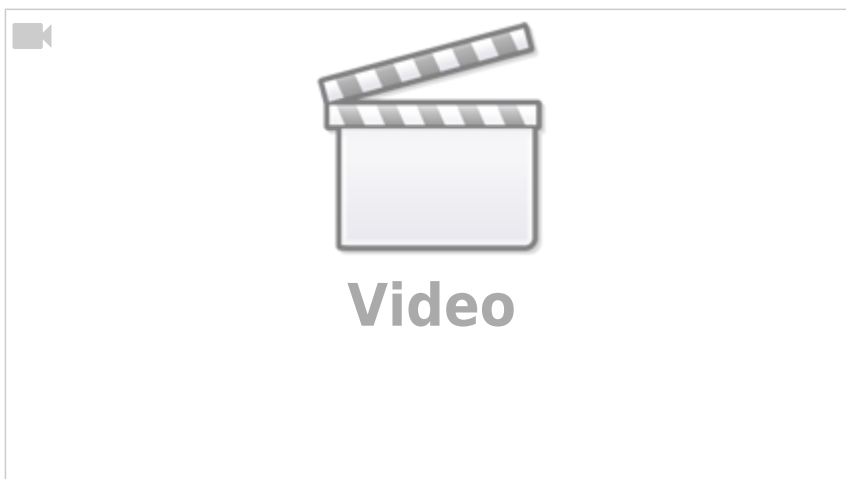

The packages are not explained in detail here. The video shows the smaller available packages. In the 3rd semester and higher we will use 0603 size resistors.

## Exercises

### Exercise 1.6.1 Pre-calculated example of resistivity

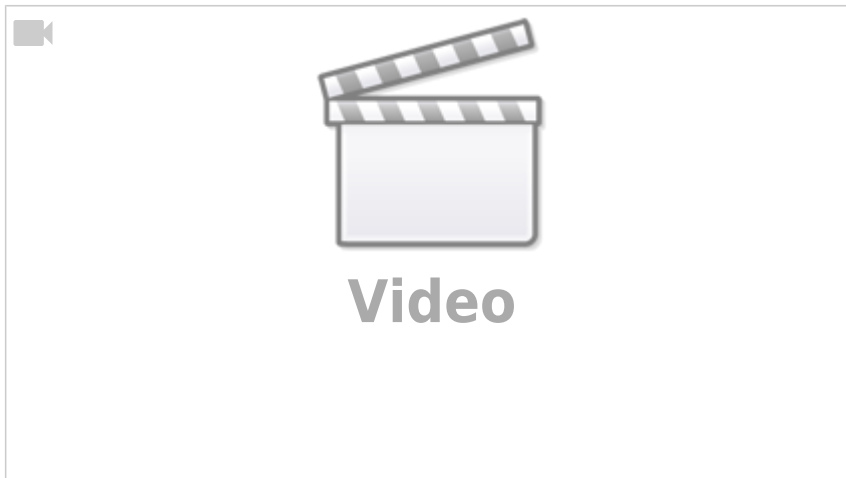

### Exercise 1.6.2 Resistance of a pencil stroke

Assume that a soft pencil lead is 100% graphite. What is the resistance of a  $5\text{cm}$  long and  $0.2\text{mm}$  wide line if it has a height of  $0.2\ \mu\text{m}$ ?

The resistivity is given by [table 5](#).

### Exercise 1.6.3 Resistance of a cylindrical coil

Let a cylindrical coil in the form of a multi-layer winding be given - this could for example occur in windings of a motor. The cylindrical coil has an inner diameter of  $d_i = 70\text{mm}$  and an outer diameter of  $d_a = 120\text{mm}$ . The number of turns is  $n_W = 1350$  turns, the wire diameter is  $d = 2.0\text{mm}$  and the specific conductivity of the wire is  $\kappa_{\text{Cu}} = 56 \cdot 10^6 \frac{\text{S}}{\text{m}}$ .

First calculate the wound wire length and then the ohmic resistance of the entire coil.

### Exercise 1.6.4 Resistance of a supply line

The supply line to a consumer has to be replaced. Due to the application, the conductor resistance must remain the same.

- The old aluminium supply cable had a specific conductivity  $\kappa_{\text{Al}} = 33 \cdot 10^6 \frac{\text{S}}{\text{m}}$  and a cross-section  $A_{\text{Al}} = 115\text{mm}^2$ .
- The new copper supply cable has a specific conductivity  $\kappa_{\text{Cu}} = 56 \cdot 10^6 \frac{\text{S}}{\text{m}}$

Which wire cross-section  $A_{\text{Cu}}$  must be selected ?

### Exercise 1.6.5 Strain gauges

t.b.d.

### Exercise 1.6.6: Temperature-dependent resistance of a winding (written test, approx. 6 % of a 60-minute written test, WS2020)

On the rotor of an asynchronous motor, the windings are designed in copper. The length of the winding wire is  $40\text{~}\text{m}$ . The diameter is  $0.4\text{~}\text{mm}$ . When the motor is started, it is uniformly cooled down to the ambient temperature of  $20\text{~}\text{C}$ . During operation the windings on the rotor have a temperature of  $90\text{~}\text{C}$ .

$$\alpha_{\text{Cu},20\text{~}\text{C}} = 0.0039 \text{~}\frac{1}{\text{K}}$$

$$\beta_{\text{Cu},20\text{~}\text{C}} = 0.6 \cdot 10^{-6} \text{~}\frac{1}{\text{K}^2}$$

$$\rho_{\text{Cu},20\text{~}\text{C}} = 0.0178 \text{~}\frac{\Omega \cdot \text{mm}^2}{\text{m}}$$

Use both the linear and quadratic temperature coefficients! 1. determine the resistance of the wire for  $T = 20\text{~}\text{C}$ .

Solution

$$\begin{aligned} R_{20\text{~}\text{C}} &= \rho_{\text{Cu},20\text{~}\text{C}} \cdot \frac{l}{A} \quad | \text{with} \\ A &= r^2 \cdot \pi = \frac{1}{4} d^2 \cdot \pi \\ R_{20\text{~}\text{C}} &= \rho_{\text{Cu},20\text{~}\text{C}} \cdot \frac{4 \cdot l}{d^2 \cdot \pi} \\ &= 0.0178 \text{~}\frac{\Omega \cdot \text{mm}^2}{\text{m}} \cdot \frac{4 \cdot 40\text{~}\text{m}}{(0.4\text{~}\text{mm})^2 \cdot \pi} \end{aligned}$$

Final result

$$R_{20\text{~}\text{C}} = 5.666 \text{~}\Omega \rightarrow 5.7 \text{~}\Omega$$

2. what is the increase in resistance  $\Delta R$  between  $20\text{~}\text{C}$  and  $90\text{~}\text{C}$  for one winding?

Solution

$$\begin{aligned} R_{90\text{~}\text{C}} &= R_{20\text{~}\text{C}} \cdot (1 + \alpha_{\text{Cu},20\text{~}\text{C}} \cdot \Delta T + \beta_{\text{Cu},20\text{~}\text{C}} \cdot \Delta T^2) \quad | \text{with } \Delta T = T_2 - T_1 = \\ &= 90\text{~}\text{C} - 20\text{~}\text{C} = 70\text{~}\text{C} = 70\text{~}\text{K} \\ \Delta R &= R_{20\text{~}\text{C}} \cdot (\alpha_{\text{Cu},20\text{~}\text{C}} \cdot \Delta T + \beta_{\text{Cu},20\text{~}\text{C}} \cdot \Delta T^2) \\ &= 5.666 \text{~}\Omega \cdot (0.0039 \text{~}\frac{1}{\text{K}} \cdot 70\text{~}\text{K} + 0.6 \cdot 10^{-6} \text{~}\frac{1}{\text{K}^2} \cdot (70\text{~}\text{K})^2) \end{aligned}$$

Final result

$$\Delta R = 1.56 \text{~}\Omega \rightarrow 1.6 \text{~}\Omega$$

## 1.7 Power and efficiency

## Goal

After this lesson you should be able to:

1. Be able to calculate the electrical power and energy across a resistor.

A nice 10 minute intro into power and efficiency (a cutout from 2:40 to 12:15 from a full video of EEVblog)

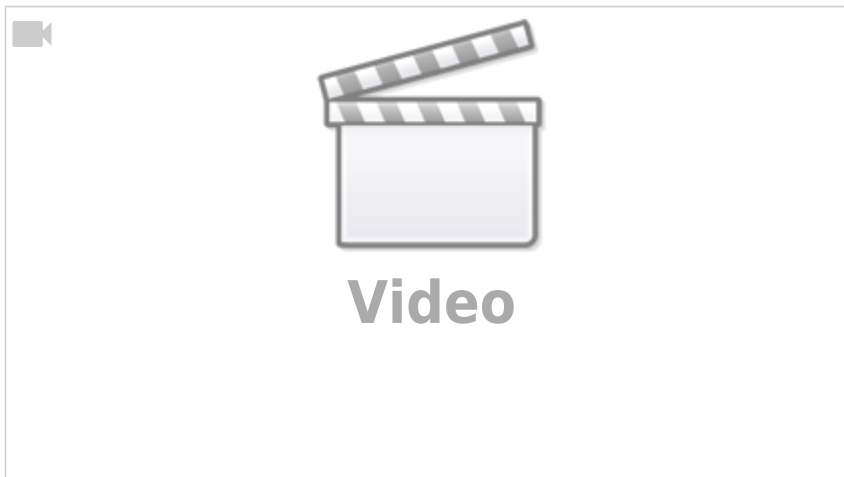

## Determining the electrical power in a DC circuit

From chapter 1.5 [Voltage, potential and energy](#) it is known that a movement of a charge across a potential difference corresponds to a change in energy. Charge transport therefore automatically means energy expenditure. Often, however, the energy expenditure per unit of time is of interest.

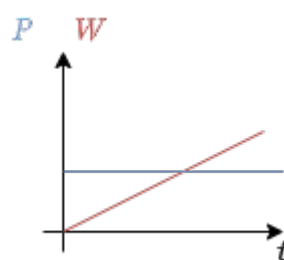

Fig. 29: Course of power and energy

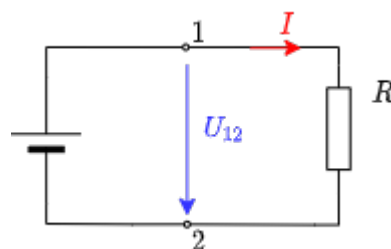

Fig. 30: Source and consumer

The energy expenditure per time unit represents the **power**:

$$\boxed{P = \frac{\Delta W}{\Delta t}}$$
 with unit  $[P] = \frac{[W]}{[t]} = 1 \frac{[J]}{[s]} = 1 \frac{[Nm]}{[s]} = 1 \text{ V} \cdot \text{A} = 1 \text{ W}$

For a constant power  $P$  and an initial energy  $W(t=0)=0$  holds:

$$\boxed{W = P \cdot t}$$

If the above restrictions do not apply, the generated/needed energy must be calculated via an integral.

In addition to the current flow from the source to the consumer (and back), the power also flows from the source to the consumer.

If we only consider a DC circuit, the following energy is converted between the terminals (see also [figure 29](#) and [figure 30](#)):

$$W = U_{12} \cdot Q = U_{12} \cdot I \cdot t$$

This gives the power (i.e. energy converted per unit time):

$$\boxed{P = U_{12} \cdot I}$$
 with the unit  $[P] = 1 \text{ V} \cdot \text{A} = 1 \text{ W} \quad \dots \quad W$  here stands for watts.

For ohmic resistors:

$$\boxed{P = R \cdot I^2 = \frac{U_{12}^2}{R}}$$

## Nominal quantities of ohmic loads

Name of the nominal quantity	physical quantity	description
Nominal power (= rated power)	$P_N$	$P_N$ is the power output of a device (consumer or generator) that is permissible in continuous operation.
Nominal current (= rated current)	$I_N$	$I_N$ is the current occurring during operation at rated power.
Nominal voltage (= rated voltage)	$U_N$	$U_N$ is the voltage occurring during operation at rated power.

## Efficiency

Fig. 31: Power flow diagram

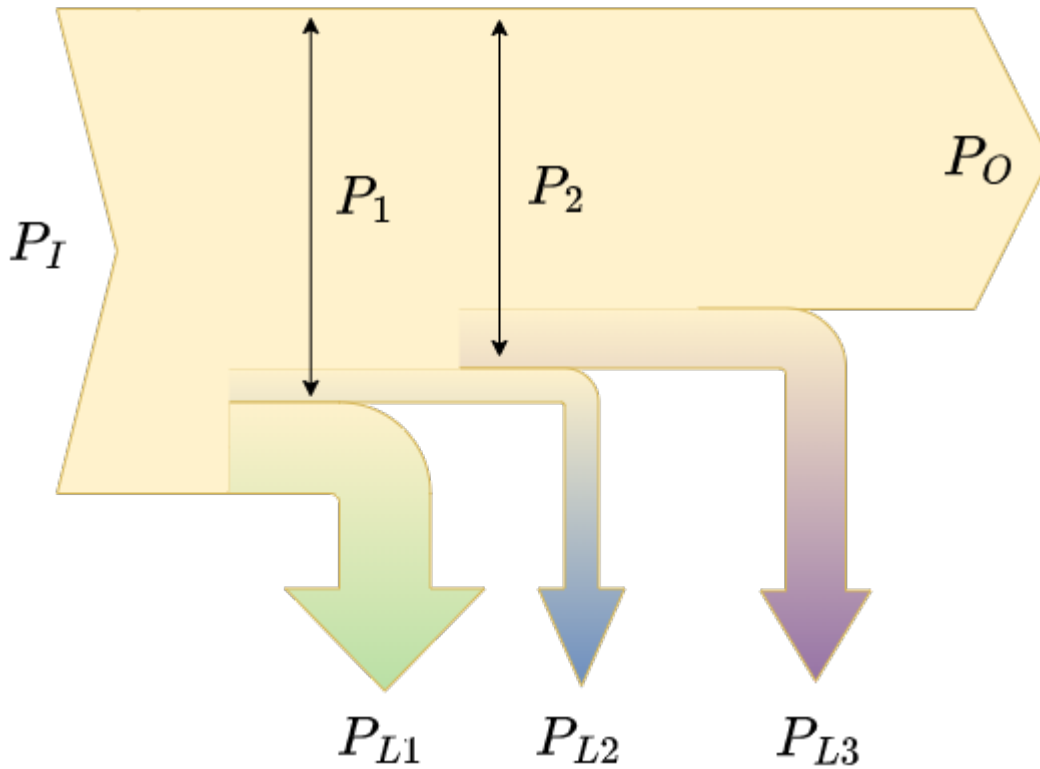
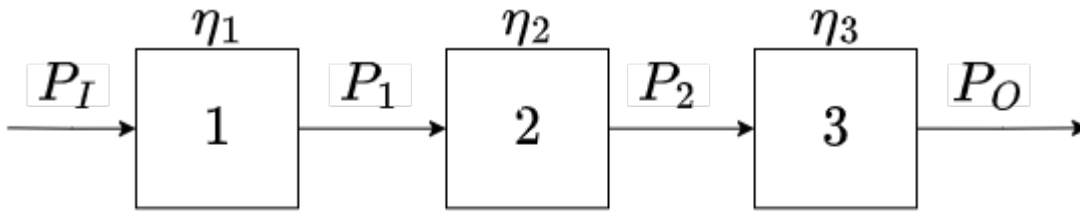

The usable (= outgoing)  $P_A$  power is always smaller than the supplied (incoming) power  $P_E$ . The difference is called power loss  $P_V$ . It is thus valid:

$$P_E = P_A + P_V$$

Instead of the power loss  $P_V$ , the efficiency  $\eta$  is often given:

$$\boxed{\eta = \frac{P_A}{P_E} \overset{!}{< 1}}$$

For systems connected in series (cf. [figure 31](#)), the total resistance is given by:

$$\boxed{\eta = \frac{P_A}{P_E} = \frac{\not{P}_1}{P_E} \cdot \frac{\not{P}_2}{\not{P}_1} \cdot \frac{P_A}{\not{P}_2} = \eta_1 \cdot \eta_2 \cdot \eta_3}$$

### Exercises

### Exercise 1.7.1 Pre-calculated example of electrical power and energy

The first 5:20 minutes is a recap of the fundamentals of calculation the electric power

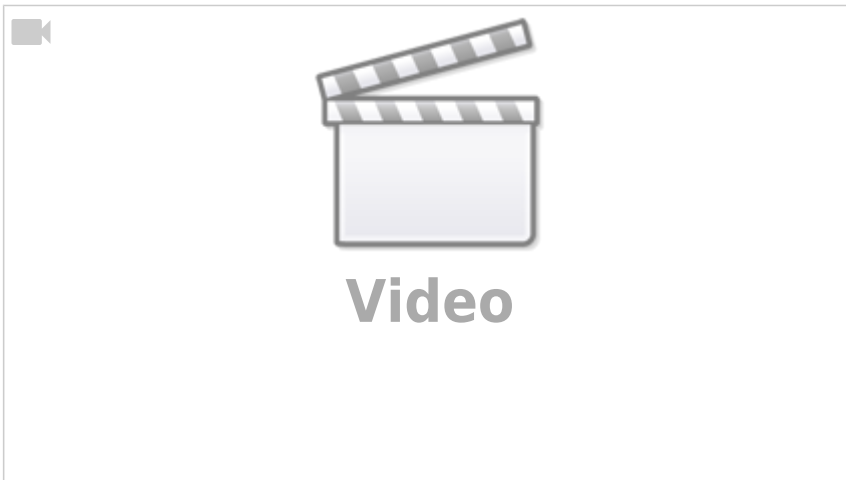

### Exercise 1.7.2 Power

A SMD resistor is used on a circuit board for current measurement. The resistance value should be  $R=0.2\ \Omega$ , the maximum power  $P_N=250\ \text{mW}$ . What is the maximum current that can be measured?

### Exercise 1.7.3 Power loss and efficiency I

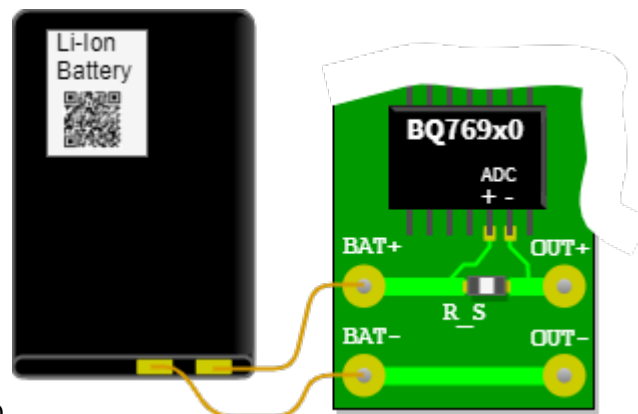

Fig. 32: Sketch of the setup

- The battery monitor BQ769x0 measures the charge and discharge currents of a lithium-ion battery by means of the voltage across a measuring resistor (shunt). In [figure 32](#) the analog-to-digital converter (ADC) of this chip is connected to the shunt  $R_S$  via the circuit board. Through the shunt the discharge current flows from the battery connection  $BAT+$  to  $OUT+$  and via  $OUT-$  back to  $BAT-$ . The shunt shall be designed so that the bipolar measurement signals have a voltage level in the range of  $-0.20\ \text{V}$  to  $+0.20\ \text{V}$ . The analog-to-digital converter has a resolution of  $15\ \mu\text{V}$ . The currents can be used to count the charge in the battery to determine the state of charge (SOC).

- Draw an equivalent circuit with voltage source (battery), measuring resistor and load resistor  $R_L$ . Also draw the measurement voltage and load voltage.
- The shunt should have a resistance value of  $1\text{m}\Omega$ . What maximum charge/discharge currents are still measurable? What minimum current change is measurable?
- What power loss is generated at the shunt in the extreme case?
- Now the efficiency is to be calculated
  - Find the efficiency as a function of  $R_S$  and  $R_L$ . Note that the same current flows through both resistors.
  - Special task: The battery is to have a nominal voltage of  $10\text{V}$  (3 cells) and the maximum discharge current is to flow. What efficiency results from the measurement alone?

### Exercise 1.7.4 Power loss and efficiency II

A water pump ( $\eta_P = 60\%$ ) has an electric motor drive ( $\eta_M = 90\%$ ). The pump has to pump  $500\text{l}$  water per minute up to  $12\text{m}$  difference in height.

- What must be the rated power of the motor?
- What current does the motor draw from the  $230\text{V}$  mains? (assumption: the  $230\text{V}$  is a DC value and also the current is DC)

### Exercise 1.7.5 PPTC

Often, parts of a circuit have to be protected from overcurrent, since otherwise components could break. This is usually done by a fuse or a circuit breaker, which open up the connection and therefore disable the path for the current. A problem with the commonly used fuses is, that once the fuse is blown (=it has been tripped) it has to be changed.

Since opening up electronics and changing the fuse is not reasonable for consumer electronics, these products nowadays use [resettable fuses](#). These consist of a polymer (=“plastics”) with conducting paths of graphite or carbon black in it. When more and more current is flowing, more and more heat is generated. At one distinct temperature, the polymer expands rapidly - which is also called phase change. This expansion moves the conducting paths apart. The system will stay in a state, where a minimum current is flowing, which maintains just enough heat dissipation for the expansion. This process is also reversible: When cooled down, the conducting paths get re-connected. These components are also called **polymer positive temperature coefficient** component or PPTC.

In the diagram below the internal structure and the resistance over the temperature is shown (more details about the structure and function can be found [here](#)).

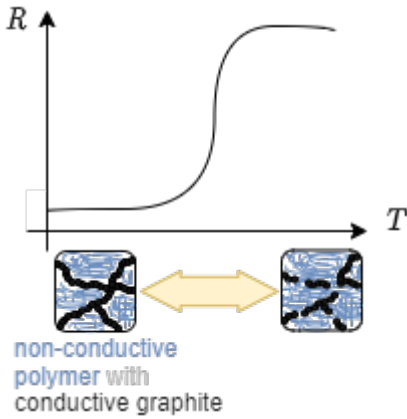

In the given circuit below, a fuse  $F$  shall protect another component shown as  $R_L$ , which could be a motor or motor driver for example. In general, the fuse  $F$  can be seen as a (temperature variable) resistance. The source voltage  $U_S$  is  $50V$  and  $R_L=250\Omega$ .

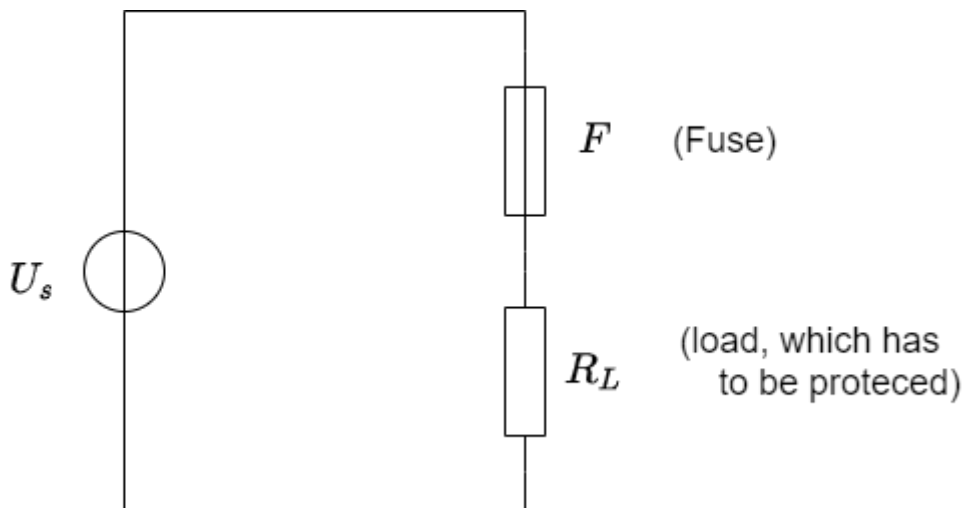

For this fuse, the component “[0ZCG0020AF2C](#)”<sup>1)</sup> is used. When this fuse trips, it has to carry nearly the full source voltage and dissipates a power of  $0.8W$ .

- First assume that the fuse is not blown. The resistance of the fuse at this is  $1\Omega$ , which is neglectable compared to  $R_L$ . What is the value of the current flowing through  $R_L$ ?
- Assuming for the next questions that the fuse has to carry the full source voltage and the given power is dissipated.
  - Which value will the resistance of the fuse have?
  - What is the current flowing through the fuse, when it is tripped?
  - Compare this resistance of the fuse with  $R_L$ . Is the assumption, that all of the voltage drops on the fuse is feasible?

## Further reading

1. [Omega Tau Nr. 303](#) : German Podcast with a researcher from the BTP (>[Physikalisch-Technische Bundesanstalt](#), Germany's national standardisation institute) on the evolution of the SI unit system.
2. [How electric flow really works](#): No, there are no free electrons in the wire, and the electrons are

not colliding with the atoms or atomic cores...

1)

the datasheet is not needed for this exercise

From:

<https://mexle.te.hs-heilbronn.de/> - MEXLE Wiki

Permanent link:

[https://mexle.te.hs-heilbronn.de/electrical\\_engineering\\_1/preparation\\_properties\\_proportions?rev=1647824292](https://mexle.te.hs-heilbronn.de/electrical_engineering_1/preparation_properties_proportions?rev=1647824292)

Last update: **2022/03/21 01:58**

