

# Exam Summer Semester 2023

## Student Group

First Name	Surname	Matrikel Nr.

## Table of Contents

- Exam Summer Semester 2023** ..... 3
  - Additional permitted Aids ..... 3
  - Hits ..... 3
  - Only EEE1-relevant Part ..... 3
    - Exercise E1 Resistivity and temperature dependent Resistance (written test, approx. 7 % of a 60-minute written test, SS2023) ..... 3
    - Exercise E1 Pure Resistor Network Simplification (written test, approx. 12 % of a 60-minute written test, SS2023) ..... 4
    - Exercise E2 Pure Resistor Network Simplification I (written test, approx. 14 % of a 60-minute written test, SS2023) ..... 6
    - Exercise E1 Equivalent Linear Source (written test, approx. 10 % of a 60-minute written test, SS2023) ..... 9
  - Full Exam ..... 12
    - Exercise E1 Resistivity and temperature dependent Resistance (written test, approx. 7 % of a 60-minute written test, SS2023) ..... 12
    - Exercise E2 Analyzing a Scope Plot (written test, approx. 12 % of a 60-minute written test, SS2023) ..... 13
    - Exercise E3 Complex voltage dividers (written test, approx. 16 % of a 60-minute written test, SS2023) ..... 14
    - Exercise E1 Pure Resistor Network Simplification (written test, approx. 12 % of a 60-minute written test, SS2023) ..... 15
    - Exercise E2 Pure Resistor Network Simplification I (written test, approx. 14 % of a 60-minute written test, SS2023) ..... 17
    - Exercise E1 Equivalent Linear Source (written test, approx. 10 % of a 60-minute written test, SS2023) ..... 20
    - Exercise E4 (Dis)Charging Capacities (written test, approx. 14 % of a 60-minute written test, SS2023) ..... 23
    - Exercise E5 Impedances at Frequencies (written test, approx. 14 % of a 60-minute written test, SS2023) ..... 24

Exercise E1 Efficiency (written test, approx. 14 % of a 60-minute written test, SS2023) ..... 25

# Exam Summer Semester 2023

## Additional permitted Aids

- non-programmable calculator,
- formulary (2 DIN A4 pages)

## Hits

- The duration of the exam is 60 min.
- Attempts to cheat will lead to exclusion and failure of the exam.
- Withdrawal is no longer possible after these exam has been handed out.
- Please write down intermediate calculations and results on the assignment sheet. (when more space is needed also on the reverse side. In this case: Mark it clearly).
- Always use units in the calculation.
- Use a document-proof, non-red pen.

## Only EEE1-relevant Part

**This part is only for about 25 minutes !**

### Exercise E1 Resistivity and temperature dependent Resistance (written test, approx. 7 % of a 60-minute written test, SS2023)

The conductivity of a dielectric material is affected by temperature. It is described by the Arrhenius law in an exponential form. In the case of a best fit would be a  $B = 1.5 \cdot 10^6$  for  $T = 20$  and  $T = 100$   $^{\circ}\text{C}$ .

The resistivity of the dielectric material is  $\rho_{\text{PP}}(20 \text{ } ^{\circ}\text{C}) = 10^{17} \text{ } \Omega\text{m}$ .

For the given material the temperature coefficients in the range of  $20 \text{ } ^{\circ}\text{C}$  and  $55$

$^{\circ}\text{C}$  are given as  $\alpha = -0.048 \text{ } 1/\text{K}$  and  $\beta = +0.00057 \text{ } 1/\text{K}^2$ .

$$R(55 \text{ } ^{\circ}\text{C}) = R(20 \text{ } ^{\circ}\text{C}) \cdot (1 + \alpha \cdot \Delta T + \beta \cdot T^2 + \dots)$$

$$= 80 \text{ } \Omega\text{m} \cdot (1 - 0.048 \text{ } 1/\text{K} \cdot (35 \text{ } \text{K}) + 0.00057 \text{ } 1/\text{K}^2 \cdot (\Delta T)^2)$$

Calculate the resistance for the dielectric material for  $20 \text{ }^\circ\text{C}$ .

Solution

$$R(20 \text{ }^\circ\text{C}) = \rho \cdot \frac{d}{A} = 10^{17} \frac{\text{m} \cdot 0.8 \cdot 10^{-6}}{1 \text{ m}^2}$$

**Exercise E1 Pure Resistor Network Simplification**  
**(written test, approx. 12 % of a 60-minute written test, SS2023)**

Calculate the voltage  $U$  in  $\text{K}$ , when switch  $S$  is closed.

Result

The values in the circuit are

Solution

$R_1 = 60 \text{ } \Omega$

The  $R_2$  and  $R_3$  are in parallel.  $S = 150 \text{ } \Omega$  is in series with the parallel combination.

$R_{\text{parallel}} = 40 \text{ } \Omega$

- $R_4 = 100 \text{ } \Omega$

The voltage divider for node  $K$  has the same proportionality as the voltage divider for node  $K'$ . Therefore, the potential of  $K$  is the same as for  $K'$ . There will be no current flow through  $R_3$ . The resistance does not create a voltage drop and therefore does not interfere with the circuit.

1. Calculate the voltage at node  $K$ , when switch  $S$  is open. It might be beneficial to redraw the circuit first.

Solution

Rearranging the circuit one can get:

Once the switch  $S$  is opened, the upper part is a parallel circuit. Therefore,  $R_{\text{eq}}$  is given as:

$$R_{\text{eq}} = (R_1 + R_2) \parallel (R_1 + R_2) + R_4 = \frac{1}{2} \cdot (R_1 + R_2) + R_4 = \frac{1}{2} \cdot (60 \Omega + 40 \Omega) + 100 \Omega$$

**Exercise E2 Pure Resistor Network Simplification I**  
**(written test, approx. 14 % of a 60-minute written test, SS2023)**

The circuit below should be given as  $U_{\text{AB}} = 60 \text{ V}$ . What is the value for  $I_{\text{AB}}$  the circuit?

Solution

$$I_{\text{AB}} = \frac{U_{\text{AB}}}{R_{\text{eq}}} = \frac{60 \text{ V}}{100 \Omega}$$

The current through the circuit is given as  $I_{\text{AB}} = \frac{U_{\text{AB}}}{R_{\text{eq}}}$ .

This current has to flow in summary through parallel branches. The voltage  $U$  in question in the upper right branch given by  $(4R \parallel 4R) + 2R + 2R$ . Its resistance is just the same as the upper left branch  $6R$ .

Therefore, half of the current flows to the left half to the right side.



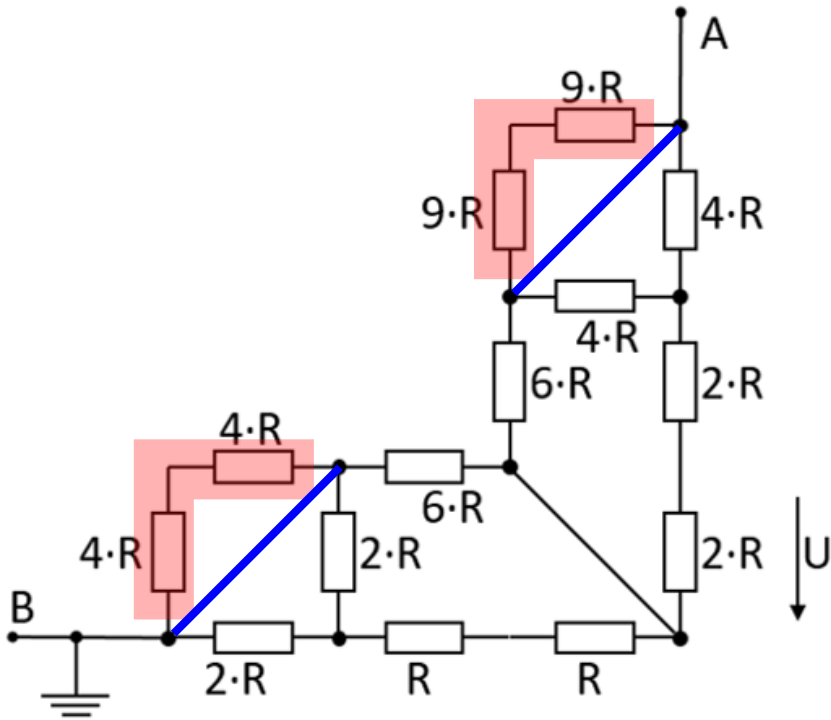

The circuit can then be rearranged for better interpretation:

Therefore,  $R_{\text{eq}}$  is given as: 
$$R_{\text{eq}} = (2R || 2R + R +$$

$$R_1 || 6R + 6R || (2R + 2R + 4R || 4R) || (R + R + R) || 6R + 6R || (2R + 2R + 2R) || \\ \&= 3R || 6R + 6R || 6R || \&= \frac{3R \cdot 6R}{3R + 6R} + 3R \end{align*}$$

**Exercise E1 Equivalent Linear Source**  
**(written test, approx. 10 % of a 60-minute written test, SS2023)**

The circuit below has to be simplified. Use equivalent linear sources for simplification.  
 Calculate the internal resistance  $R_{\text{i}}$  and the source voltage  $U_{\text{s}}$  of an equivalent linear voltage source.

- $R_1 = 5 \text{ } \Omega$
- $U_1 = 10 \text{ V}$
- $R_2 = 5 \text{ } \Omega$
- $I_3 = 0.5 \text{ A}$
- $R_4 = 10 \text{ } \Omega$
- $U_5 = 4 \text{ V}$

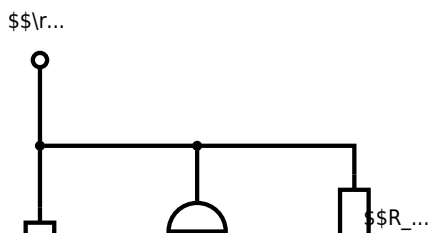

### Solution

The principle idea here is to find parts of the circuit which are already a linear (voltage or current) source. Then this can be transformed into the equivalent other source, as shown in the next picture.

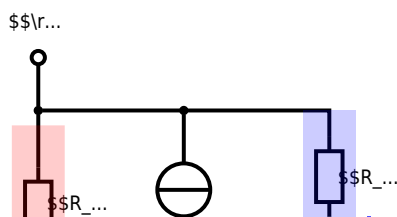

In order to get the currents one has to calculate it by  $I_x = \frac{U_x}{R_x}$

$$\begin{aligned} I_0 &= \frac{U_0}{R_1} = \frac{10 \text{ V}}{5 \Omega} = 2 \text{ A} \\ I_5 &= \frac{U_5}{R_4} = \frac{4 \text{ V}}{10 \Omega} = 0.4 \text{ A} \end{aligned}$$

$I_3$  and  $I_0$  can be combined to  $I_{03} = I_0 - I_3$  facing upwards:

$$I_{03} = 1.5 \text{ A}$$

Then, the linear current source  $I_{03}$  with  $R_1$  gets transformed into a linear voltage source with  $U_{03} = R_1 \cdot I_{03}$  facing down.

$$U_{03} = 7.5 \text{ V}$$

Then, the resistors  $R_1$  and  $R_2$  can be combined to  $R_{12} = R_1 + R_2$ .

After this, the next step is to make a linear current source out of  $U_{03}$  and  $R_{12}$ . The current will be  $I_{0123} = \frac{U_{03}}{R_{12}}$ , facing up again.

$$I_{0123} = 0.6 \text{ A}$$

The second-last step is the sum up of the current sources  $I_{0123}$  and  $I_5$  as  $I_{01235} = I_{0123} - I_5$  and the resistors as  $R_{124} = R_{12} || R_4$ .

$$I_{01235} = 0.2 \text{ A} \quad R_{124} = 5.55 \Omega$$



Calculate the resistance for the dielectric material for  $20 \text{ }^\circ\text{C}$ .

Solution

$$R(20 \text{ }^\circ\text{C}) = \rho \cdot \frac{d}{A} = 10^{17} \frac{\Omega \cdot \text{m} \cdot 0.8 \cdot 10^{-6} \text{ m}}{1 \text{ m}^2}$$

[electrical\\_engineering\\_and\\_electronics:task\\_kyt15w11e3sempb2\\_with\\_calculation](#)  
resistivity, power, exam ee1 ss2023

### Exercise E2 Analyzing a Scope Plot (written test, approx. 12 % of a 60-minute written test, SS2023)

1. What is the RMS value of a sine wave with a peak-to-peak value of 10 V and a phase shift of  $45^\circ$  (in radians and degree)?

**Result:** measured current curve shall be visible as a dashed line.

**The continuous line shows the voltage.**

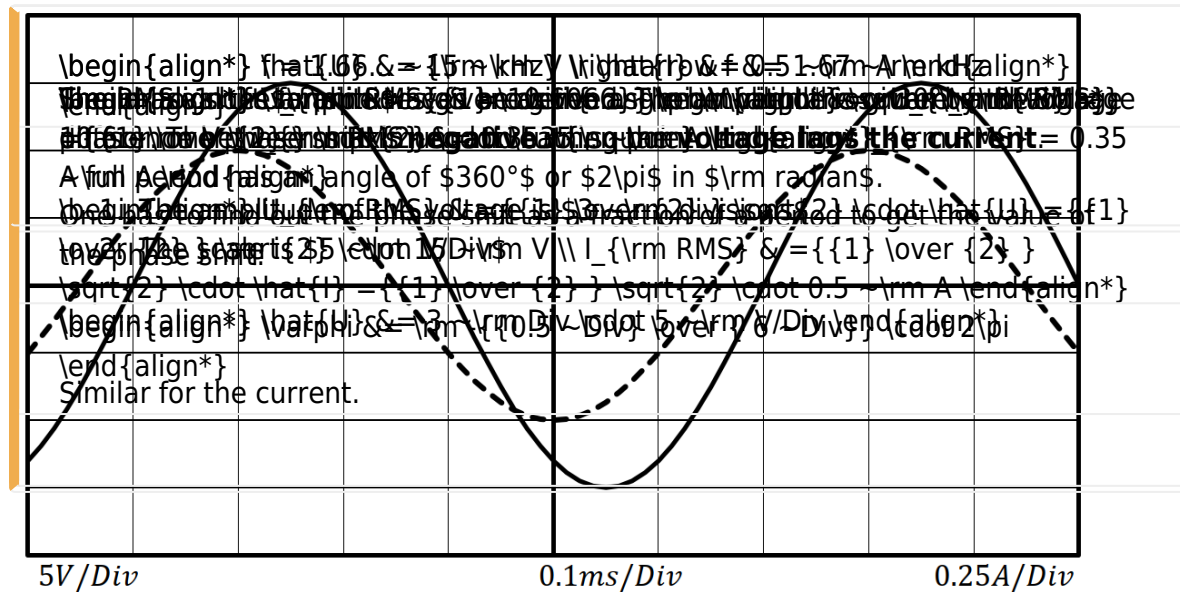

Use the correct symbols and units in your answers!

1. Calculate the frequency  $f$  of the periodic signals.

Solution

Frequency  $f$  is given by the period  $T$ . The period can be measured in the image of the scope.

1. The sine waves repeat after  $6 \text{ ~}\text{Div}$  (e.g. from falling turning point to falling turning point of one curve)
2. The scale is  $0.1 \text{ ~}\text{ms/Div}$

$$f = \frac{1}{T} \quad T = 6 \text{ ~}\text{Div} \cdot 0.1 \text{ ~}\text{ms/Div}$$

$$\rightarrow f = \frac{1}{6 \text{ ~}\text{Div} \cdot 0.1 \text{ ~}\text{ms/Div}}$$

[electrical\\_engineering\\_and\\_electronics:task\\_1m3izw2szosswtto\\_with\\_calculation\\_exam\\_ee1\\_ss2023](#)

### Exercise E3 Complex voltage dividers

(written test, approx. 16 % of a 60-minute written test, SS2023)

**Task:** Draw the two impedances in this circuit, resulting phase shift between

Result:  $U_a$  drag  $\phi$ . Choose an appropriate scaling factor and write it down.

- $R = 1.1 \text{ ~}\text{k}\Omega$

$$\underline{Z}_L = 3.5 \cdot 10^{-3} \text{ j} \cdot 2\pi \cdot 150 \cdot 10^3 = 3.5 \cdot 10^{-3} \cdot 9.42 \cdot 10^6 \text{ j} = 3.297 \cdot 10^4 \text{ j} \Omega$$

$$\underline{U}_O = \underline{U}_I \cdot \frac{R}{R + \underline{Z}_L} = 0.5 \text{ V} \cdot \frac{10 \text{ k}\Omega}{10 \text{ k}\Omega + 3.297 \cdot 10^4 \text{ j} \Omega}$$

The formula to start with is the (complex) voltage divider: 
$$\underline{U}_O = \underline{U}_I \cdot \frac{R}{R + \underline{Z}_L}$$

At the off-frequency the absolute values of impedances  $Z_L$  is equal to  $R$ . This leads to 
$$\frac{R}{R + \underline{Z}_L} = \frac{1}{\sqrt{2}}$$

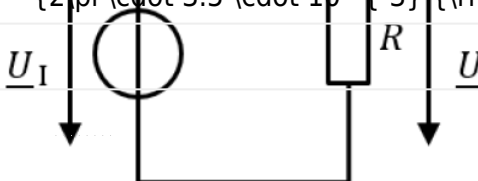

1. Calculate the impedance  $\underline{Z}_L$ .

Solution

$$\underline{Z}_L = \text{j} \cdot \omega \cdot L = \text{j} \cdot 2\pi \cdot 150 \text{ kHz} \cdot 3.5 \text{ mH}$$

[electrical\\_engineering\\_and\\_electronics:task\\_c9f15i7l797equis\\_with\\_calculation](#)  
[impedance, phasor, cutoff, exam ee1 ss2023](#)

**Exercise E1 Pure Resistor Network Simplification**  
**(written test, approx. 12 % of a 60-minute written test, SS2023)**

Calculate the voltage  $U_K$ , when switch  $S$  is closed.  
 Result

The values in the circuit are  
 Solution

- $R_1 = 60 \Omega$
- $R_2 = 40 \Omega$
- $R_3 = 40 \Omega$
- $R_4 = 150 \Omega$

The voltage divider node  $K$  has the same proportionality as the voltage divider node  $K'$ . Therefore, the potential of  $K$  is the same as for  $K'$ . There will be no current flow through  $R_3$ . The resistance does not create a voltage drop and therefore does not interfere with the circuit.

1. Calculate the voltage at node  $K$ , when switch  $S$  is open.  
It might be beneficial to redraw the circuit first.

Solution

Rearranging the circuit one can get:

Once the switch  $S$  is opened, the upper part is a parallel circuit. Therefore,  $R_{\text{eq}}$  is given as:

$$R_{\text{eq}} = \frac{1}{\frac{1}{R_1 + R_2} + \frac{1}{(R_1 + R_2) + R_4}} \cdot (R_1 + R_2) + R_4 = \frac{1}{\frac{1}{2} + \frac{1}{60 + 40}} \cdot (60 + 40) + 100 = 100 \Omega$$

[electrical\\_engineering\\_and\\_electronics:task\\_cgeyprm6oboukcci\\_with\\_calculation\\_network\\_simplification, exam ee1 ss2023](#)

**Exercise E2 Pure Resistor Network Simplification I (written test, approx. 14 % of a 60-minute written test, SS2023)**

The circuit below voltage is given by  $U_{\text{AB}} = 60 \text{ V}$ . What is the value for  $I_{\text{AB}}$  in the circuit?

Solution

$$I_{\text{AB}} = \frac{U_{\text{AB}}}{R_{\text{eq}}} = \frac{60 \text{ V}}{100 \Omega} = 0.6 \text{ A}$$

The current through the circuit is given as  $I_{\text{AB}} = \frac{U_{\text{AB}}}{R_{\text{eq}}}$ .

This current has to flow in summary through parallel branches. The voltage  $U$  in question in the upper right branch given by  $(4R || 4R) + 2R + 2R$ . Its resistance is just the same as the upper left branch  $6R$ .

Therefore, half of the current flows to the left half to the right side.  
 The voltage  $U$  is consequently: 
$$U = \frac{I_{AB}}{2 \cdot R_{eq}} = \frac{U_{AB} \cdot 2R}{2 \cdot R_{eq}}$$
  

$$= \frac{60 \text{ V}}{5}$$

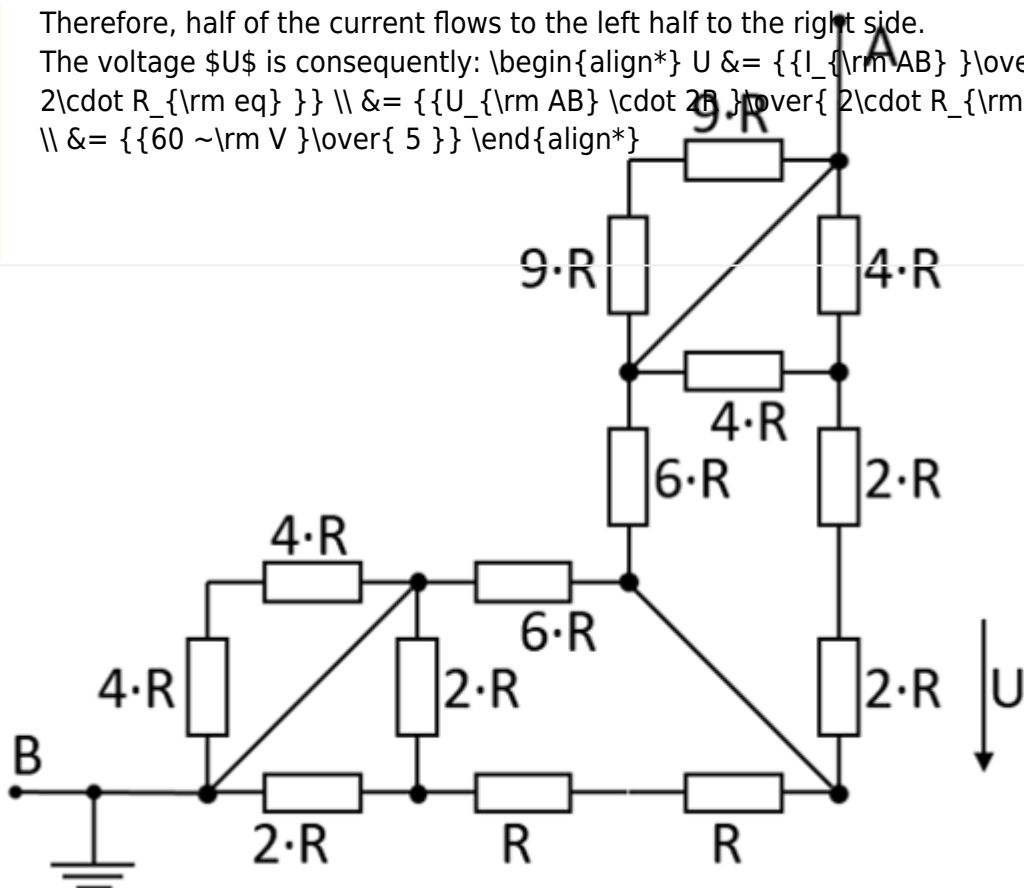

1. What is the equivalent resistance  $R_{eq}$ ?

Solution

Part of the circuit is shorted. Here the resistors (marked in red) are shorted by the connections marked in blue:

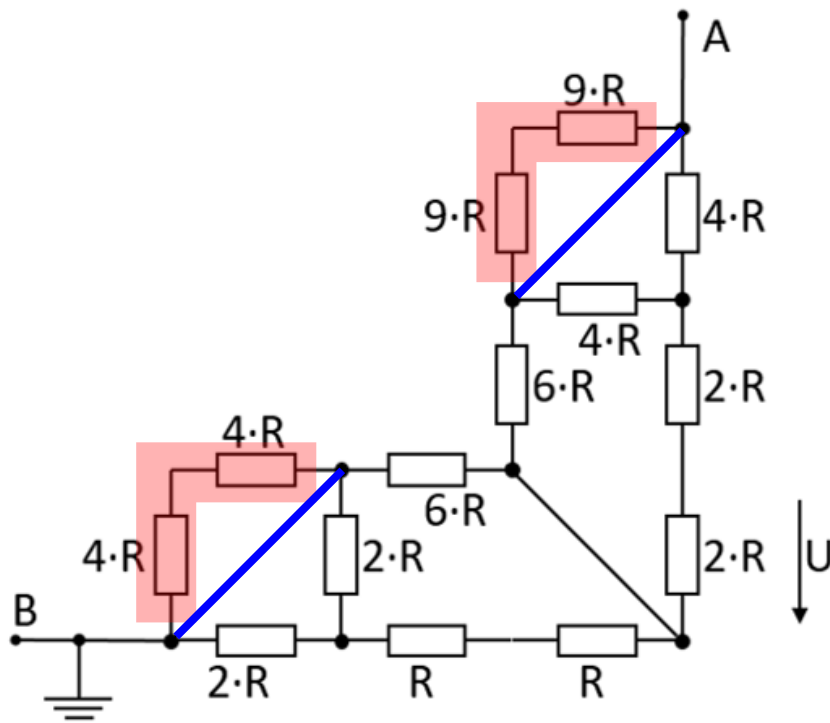

The circuit can then be rearranged for better interpretation:

Therefore,  $R_{\text{eq}}$  is given as: 
$$R_{\text{eq}} = (2R \parallel (2R + R)) \parallel 6R + 6R \parallel ((2R + 2R + 4R) \parallel 4R) \parallel ((R + R + R) \parallel 6R + 6R \parallel (2R + 2R))$$

$$+ 2R) \parallel \&= 3R \parallel 6R \&\&+ 6R \parallel 6R \parallel \&= \frac{3R \cdot 6R}{3R+6R} \&\&+ 3R \parallel$$

$$\end{align*}$$

[electrical\\_engineering\\_and\\_electronics:task\\_erlctd760zmvox0t\\_with\\_calculation\\_network\\_simplification, exam ee1 ss2023](#)

### Exercise E1 Equivalent Linear Source

(written test, approx. 10 % of a 60-minute written test, SS2023)

The circuit below has to be simplified. Use equivalent linear sources for simplification. Calculate the internal resistance  $R_{\text{i}}$  and the source voltage  $U_{\text{s}}$  of an equivalent linear voltage source.

- $R_1 = 5 \text{ } \Omega$
- $U_{\text{AB}} = 1.11 \dots \text{ V}$
- $R_{\text{i}} = 5.55 \dots \text{ } \Omega$
- $I_3 = 0.5 \text{ A}$
- $R_4 = 10 \text{ } \Omega$
- $U_5 = 4 \text{ V}$

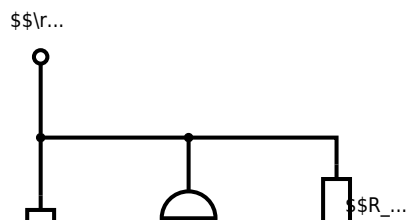

### Solution

The principle idea here is to find parts of the circuit which are already a linear (voltage or current) source. Then this can be transformed into the equivalent other source, as shown in the next picture.

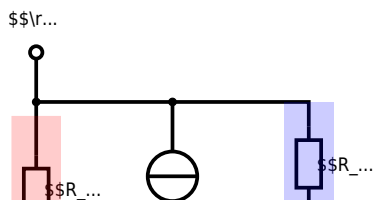

In order to get the currents one has to calculate it by  $I_x = \frac{U_x}{R_x}$

$$I_0 = \frac{U_0}{R_1} = \frac{10 \text{ V}}{5 \text{ } \Omega} = 2 \text{ A}$$

$$I_5 = \frac{U_5}{R_4} = \frac{4 \text{ V}}{10 \text{ } \Omega} = 0.4 \text{ A}$$

$I_3$  and  $I_0$  can be combined to  $I_{03} = I_0 - I_3$  facing upwards:

$$I_{03} = 1.5 \text{ A}$$

Then, the linear current source  $I_{03}$  with  $R_1$  gets transformed into a linear voltage source with  $U_{03} = R_1 \cdot I_{03}$  facing down.

$$U_{03} = 7.5 \text{ V}$$

Then, the resistors  $R_1$  and  $R_2$  can be combined to  $R_{12} = R_1 + R_2$ .

After this, the next step is to make a linear current source out of  $U_{03}$  and  $R_{12}$ . The current will be  $I_{0123} = \frac{U_{03}}{R_{12}}$ , facing up again.

$$I_{0123} = 0.6 \text{ A}$$

The second-last step is the sum up of the current sources  $I_{0123}$  and  $I_5$  as  $I_{01235} = I_{0123} - I_5$  and the resistors as  $R_{124} = R_{12} || R_4$ .

$$I_{01235} = 0.2 \text{ A} \quad R_{124} = 5.55 \dots \text{ } \Omega$$

The final step is the back-transformation to a linear voltage source, with  $U_{\text{rm}}$

$$AB\} = R_{124} \cdot I_{01235}$$

The simplest and fastest (= for exams) is to work with interim results in the calculation.

Here, there there is also a full final formula given:

$$\begin{aligned} U_{\text{rms}} &= U_{\text{AB}} = I_{01235} \cdot R_{124} \\ &= (I_{0123} - I_5) \cdot (R_{12} \parallel R_4) = \left( \frac{U_{03}}{R_{12}} - I_5 \right) \cdot \left( (R_1 + R_2) \parallel R_4 \right) \\ &= \left( \frac{R_1 \cdot I_{03}}{R_1 + R_2} - I_5 \right) \cdot \left( (R_1 + R_2) \parallel R_4 \right) \\ &= \left( \frac{R_1 \cdot \left( \frac{U_0}{R_1} - I_3 \right)}{R_1 + R_2} - I_5 \right) \cdot \left( (R_1 + R_2) \parallel R_4 \right) \end{aligned}$$

[electrical\\_engineering\\_and\\_electronics:task\\_lefcuaxiu8ewcr9\\_with\\_calculation\\_network\\_simplification, equivalent sources, exam ee1 ss2023](#)

### Exercise E4 (Dis)Charging Capacities

(written test, approx. 14 % of a 60-minute written test, SS2023)

The circuit in the drawing is initially in the state shown in the drawing. At  $t = 0$  s, the switch  $S_1$  switches to the situation shown in the drawing. What is the new time constant?

- $C = 200 \text{ nF}$

Solution:  $R = 8.0 \text{ k}\Omega$

Solution:  $\tau = 0.16 \text{ ms}$

$$U_{\text{max}} = U_0 \cdot \frac{R_1}{R_1 + R_2} = 10 \text{ V} \cdot \frac{17 \text{ k}\Omega}{17 \text{ k}\Omega + 3 \text{ k}\Omega} = 7.69 \text{ V}$$

Again, the time constant generally gives the time for the capacitor to charge to  $0.632 \cdot U_{\text{max}}$ . Without the parallel resistors, the current source would charge the capacitor "to infinity" ( $U_C \rightarrow \infty$ ). This is here limited by the parallel resistors. When  $S_2$  is closed, then, the source  $U$  drives the current through the series circuit given by  $R_3$ ,  $C$ ,  $R_1$  and  $R_2$ .

$$U_{\text{max}} = U \cdot \frac{R_1}{R_1 + R_2} = 25 \text{ V} \cdot \frac{17 \text{ k}\Omega}{17 \text{ k}\Omega + 3 \text{ k}\Omega} = 20.4 \text{ V}$$

This is also the maximum voltage on the capacitor, since it is in parallel with the resistors.

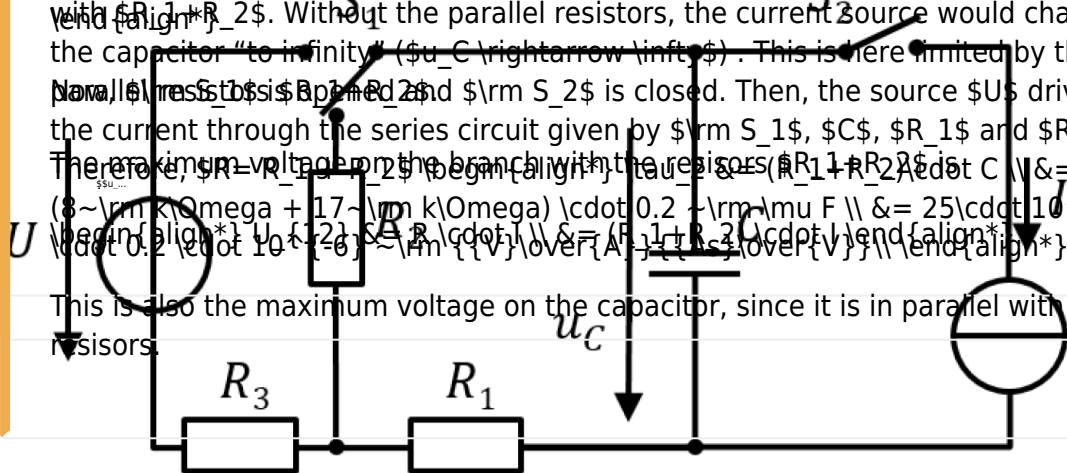

Before  $t = 0$  s all switches are switched as shown and the capacitor is fully discharged. At  $t = 0$  s the switch  $S_1$  shall switch to the voltage source.

1. Calculate the time constant for charging the capacitor.

Solution

The time constant is generally given as:  $\tau = R \cdot C$

Once  $S_1$  is closed and  $S_2$  is open at  $t_0$ , the source  $U$  drives the current through the series circuit given by  $S_1$ ,  $C$ ,  $R_1$  and  $R_3$ .  
Therefore,  $R = R_1 + R_3$   
 $\tau = (R_1 + R_3) \cdot C = (8 \text{ k}\Omega + 7 \text{ k}\Omega) \cdot 0.2 \text{ }\mu\text{F} = 15 \cdot 10^3 \cdot 0.2 \cdot 10^{-6} \text{ s} = 3 \text{ ms}$

...

Solution

Both courses of the voltage for charging and discharging are described with an exponential function. However, the curve for charging increases first steep and flattens out for longer time scales ( $\propto (1 - e^{-x})$ ).

[electrical\\_engineering\\_and\\_electronics:task\\_p8yrdjr60k6bvc4n\\_with\\_calculation\\_charging, capacities, exam ee1 ss2023](#)

## Exercise E5 Impedances at Frequencies



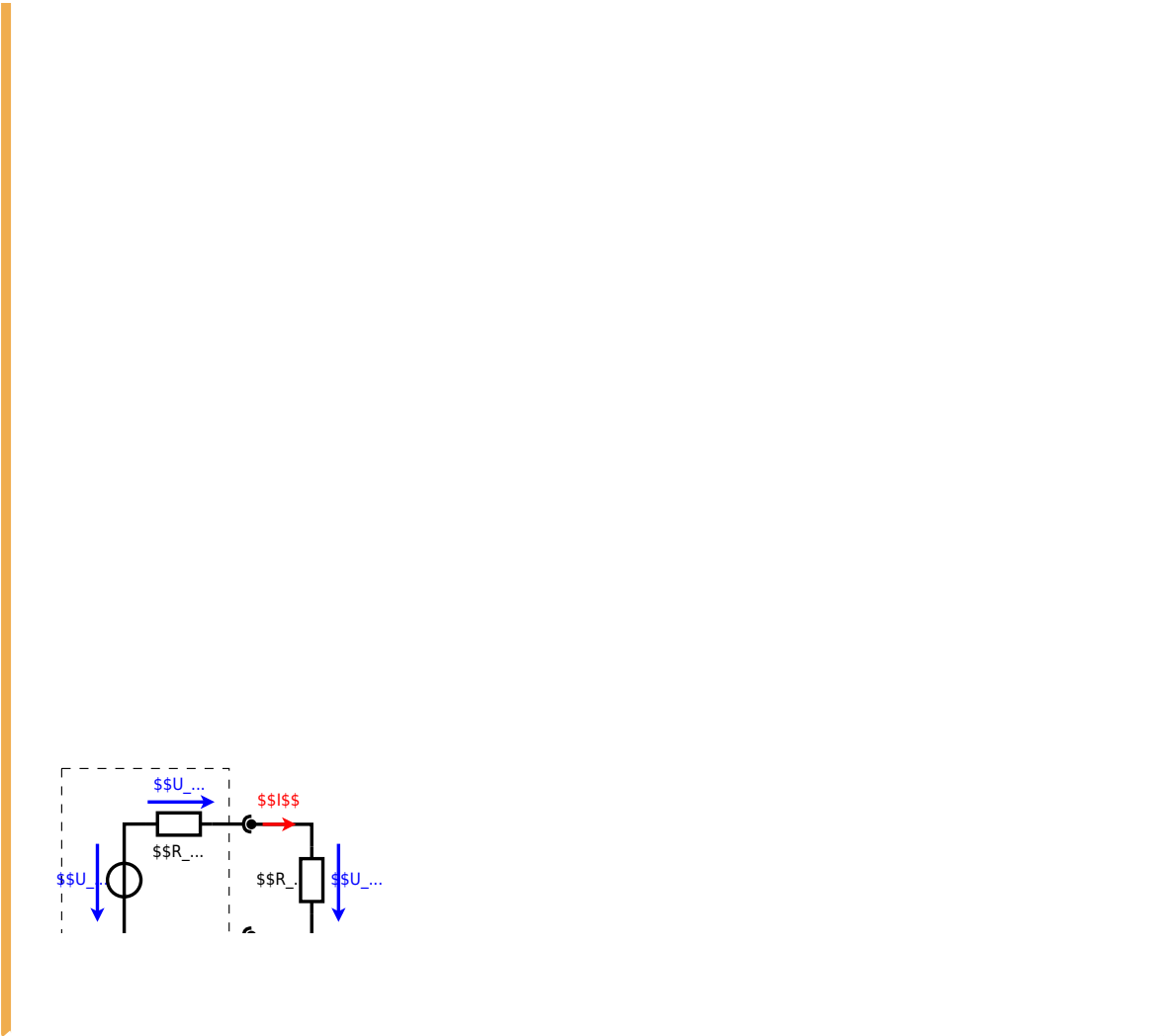

electrical\_engineering\_and\_electronics:task\_w3wf215v2u98ty07\_with\_calculation  
efficiency, charges, power, exam ee1 ss2023

From:  
<https://mexle.te.hs-heilbronn.de/> - **MEXLE Wiki**

Permanent link:  
[https://mexle.te.hs-heilbronn.de/electrical\\_engineering\\_and\\_electronics\\_1/ss2023\\_exam](https://mexle.te.hs-heilbronn.de/electrical_engineering_and_electronics_1/ss2023_exam)

Last update: **2026/01/12 00:31**

